

Jan Erik Gulbrandsen • Arve Melhus

# *nye* MEGA 8

Matematikk for ungdomstrinnet/ungdomssteget

---

**Fasit**

**Grunnbok 8A**

© N.W. Damm & Søn, 2007

3. utgave

2. opplag

Materialet i denne publikasjonen er omfattet av åndsverklovens bestemmelser. Uten særskilt avtale med N. W. Damm & Søn AS er enhver eksemplarframstilling og tilgjengeliggjøring bare tillatt i den utstrekning det er hjemlet i lov eller tillatt gjennom avtale med Kopinor, interesseorgan for rettighetshavere til åndsverk.

Redaktør: Marianne Haanæs

Omslag: RenaissanceMedia AS

Illustrasjoner: Eivinn A. Fjellhammer

Grafisk tilrettelegging og sats: RenaissanceMedia AS

Skrift: Century Old Style 10pt

Papir: 115 g Arctic Volum

Trykk: Narayana Press, Danmark, 2007

ISBN 978-82-04-12938-3



A11

a)

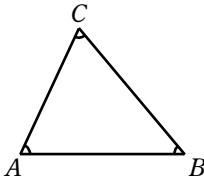

b)

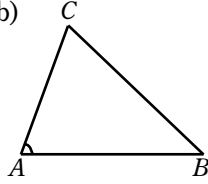

c)

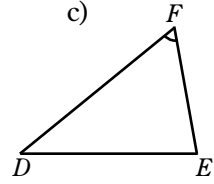

A13

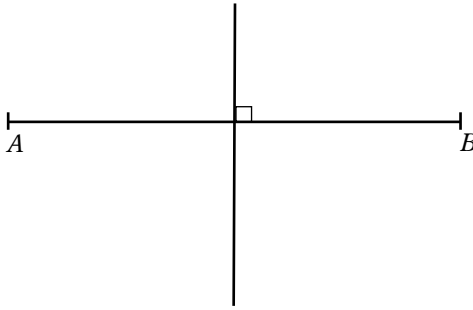

A 14

a)

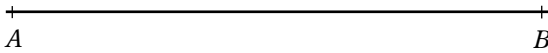

b)

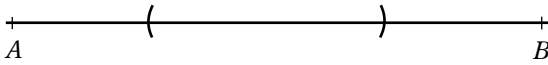

c)

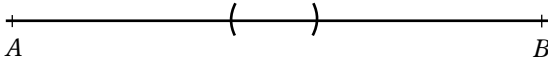

d)

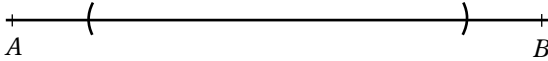

- e) De er symmetrisk plasserte i forhold til midtpunktet./  
Dei er symmetrisk plasserte rundt midtpunktet.

A 15

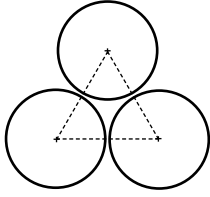

Likesidet trekant/Likesida trekant

A 16

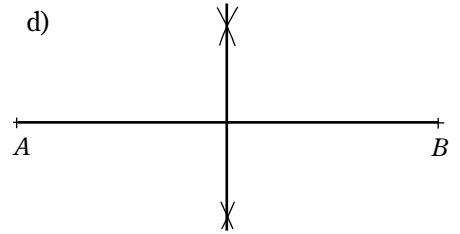
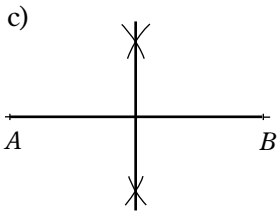
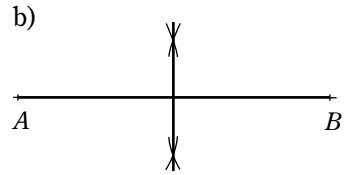
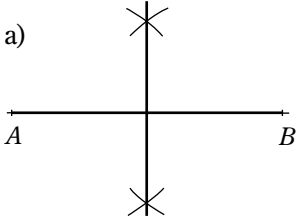

A 17

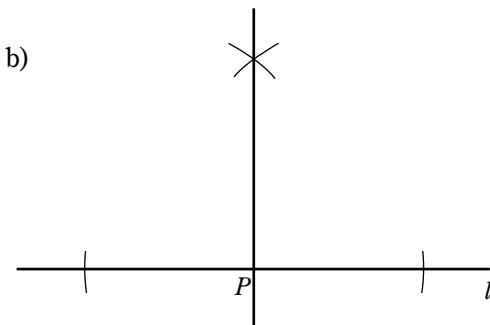
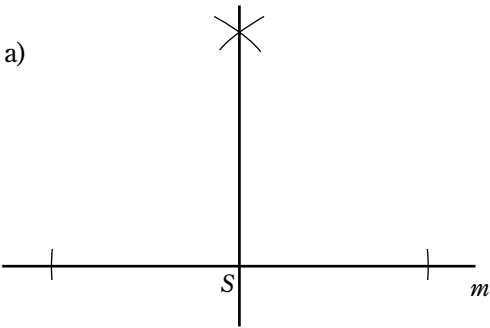

A 18

Konstruer normalen fra  $P$  på  $l$ , og mål afstanden fra  $P$  til punktet normalen krysser  $l$ . / Konstruer normalen fra  $P$  på  $l$ , og mål afstanden fra  $P$  til punktet normalen krysser  $l$ .

A 19

a) Linje 2

b) Det er normalen fra  $P$  på  $l$ . / Det er normalen fra  $P$  på  $l$ .

A 20

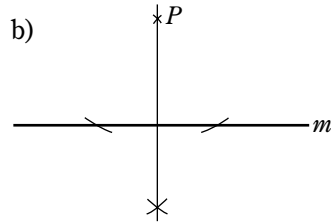
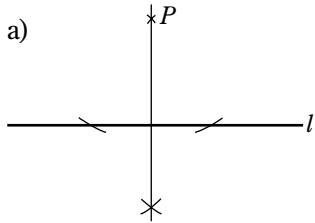

A 21

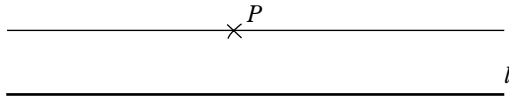

A 22

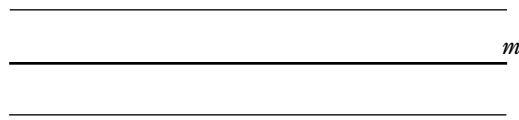

A 23

$AB \parallel ST$ ,  $CD \parallel KL$ , og  $EF \parallel IJ \parallel QR$

A 24

Linjestykke 2

A 25

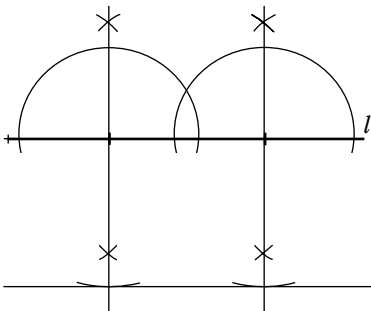

A 26

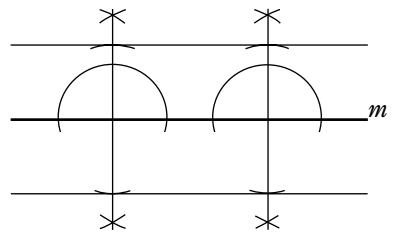

A 27

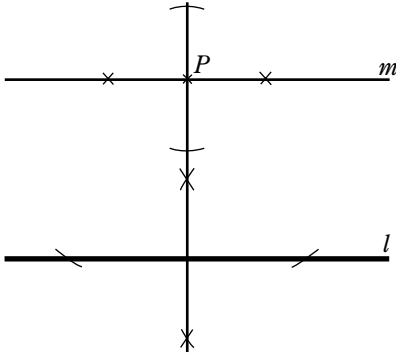

A 28

a)

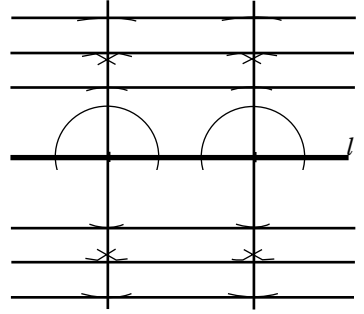

A 30

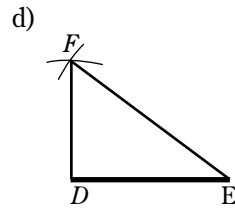
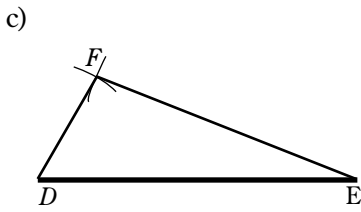
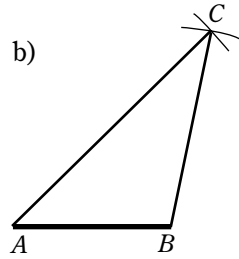
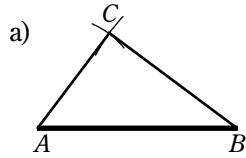

A 31

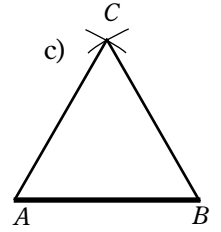
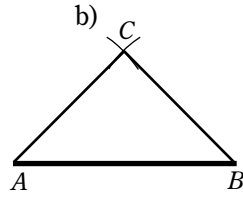
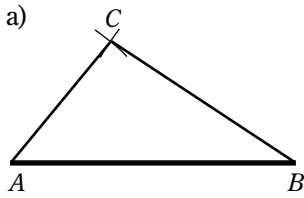

A 32

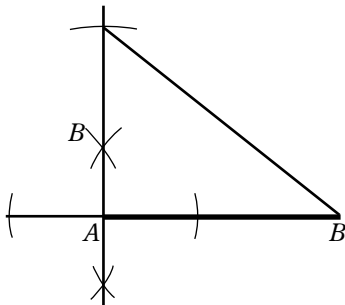

A 35

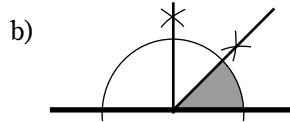
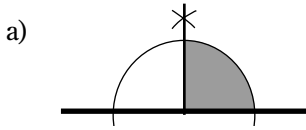

c) 45°

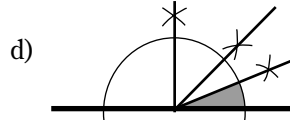

A 36

a) 135°

b) 67,5°

A 37

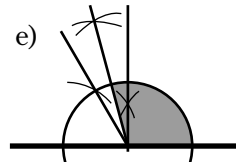
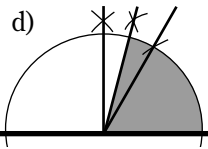
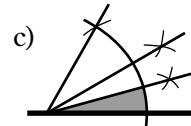
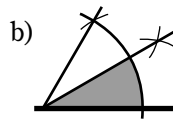
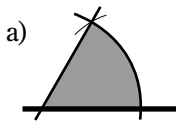

A 38

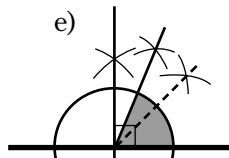
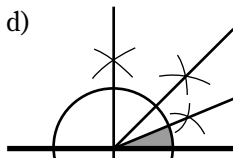
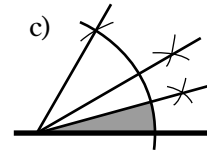
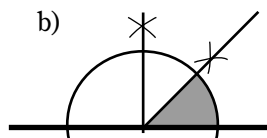
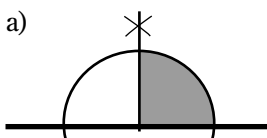



A 39

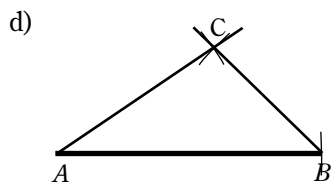
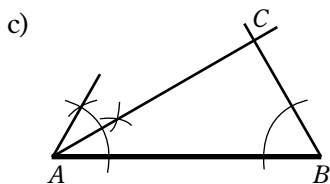
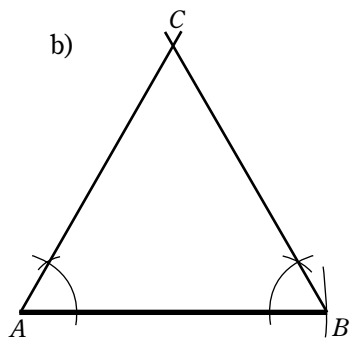
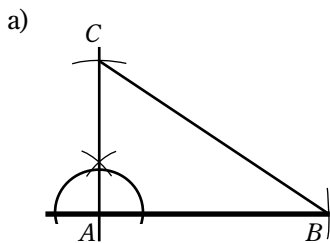

A 40

- a)  $\angle A = \angle BAC$ ,  $\angle B = \angle ABC$  og  $\angle C = \angle ACB$   
 b)  $\angle D = \angle EDF$ ,  $\angle E = \angle DEF$  og  $\angle F = \angle DFE$   
 c)  $\angle X = \angle YXZ$ ,  $\angle Y = \angle XYZ$  og  $\angle Z = \angle XZY$   
 d)  $\angle K = \angle LKM$ ,  $\angle L = \angle KLM$  og  $\angle M = \angle KML$

A 41

- a)  $100^\circ$       b)  $60^\circ$       c)  $70^\circ$       d)  $20^\circ$

A 42

$\angle E = 60^\circ$

A 43

- a, b og c)

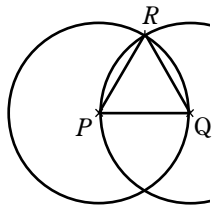

d,g)  $\angle QPR = \angle RQP = \angle PRQ = 60^\circ$

e, f)  $PQ = PR = QR$

A 44

a, b, c)

$AC = BC$ , og  $\angle BAC = \angle ABC$

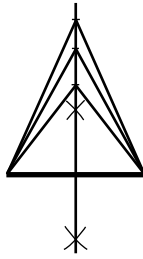

d)  $AD = BD$ , og  $\angle BAD = \angle ABD$

e)  $AE = BE$ , og  $\angle BAE = \angle ABE$

A 45

a) Rettvinklet trekant/  
Rettvinkla trekant

b) Likesidet trekant/  
Likesida trekant

c) Likebeint trekant

d) Rettvinklet og likebeint trekant/  
Rettvinkla og likebeint trekant

e) Rettvinklet trekant/  
Rettvinkla trekant

f) Likesidet trekant/  
Likesida trekant

A 46

a)

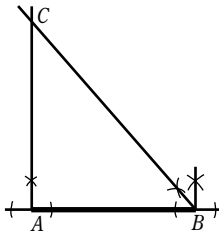

b)

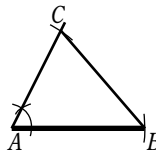

c)

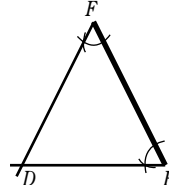

Likesidet trekant/  
Likesida trekant

d)

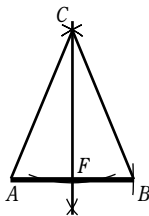

$\Delta ABC$  er en likebeint trekant.  
 $AF = 3$  cm. Midtnormalen halverer linjestykket  $AB$ .

A 47

a)

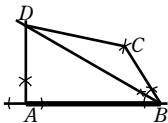

b)

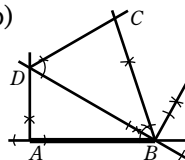

c)

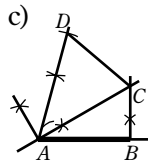

d)

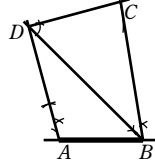

A 48

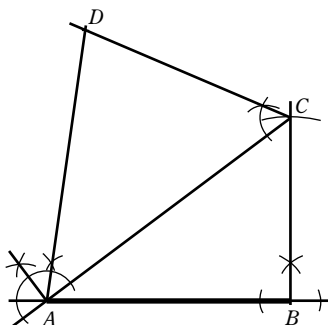

A 49

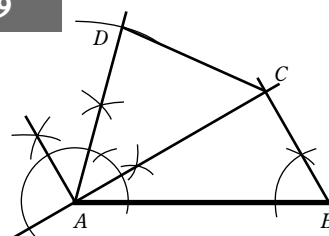

## BLÅ

**A 50** a) 9 cm    b) 5,5 cm    c) 10 cm    d) 4,7 cm    e) 7,3 cm

**A 52** a) 1) 3,8 cm                      2) 4,3 cm                      3) 8,1 cm                      4) 10,5 cm  
b) 1) 38 mm                      2) 43 mm                      3) 81 mm                      4) 105 mm

**A 53** a) Tone 410 cm    b) 45 cm  
Iver 3,87 m  
Gaute 3820 mm    c) 13 cm  
Liv 380 cm  
Nina 3680 mm  
Svenn 36,5 dm

**A 54** a) 1,4 dm > 9,0 cm                      b) 1,4 dm er 5 cm lengre enn 9,0 cm

**A 55** a) Den røde/Den raude    b) 0,8 cm

**A 57** a) 7,32 m = 73,2 dm = 732 cm = 7320 mm  
2,44 m = 24,4 dm = 244 cm = 2440 mm  
b) 3,0 m = 30,0 dm = 300 cm = 3000 mm  
2,0 m = 20,0 dm = 200 cm = 2000 mm  
c) 1,83 m = 18,3 dm = 183 cm = 1830 mm  
1,22 m = 12,2 dm = 122 cm = 1220 mm  
d) 3,5 m = 35,0 dm = 350 cm = 3500 mm  
2,1 m = 21,0 dm = 210 cm = 2100 mm

**A 58** a) 40°, spiss vinkel                      b) 90°, rett vinkel                      c) 115°, stump vinkel

**A 59** a) 90°    b) 60°    c) 30°  
d) 150°    e) 210°    f) 270°

**A 61** a) Spiss vinkel    b) Spiss vinkel    c) Stump vinkel  
d) Rett vinkel    e) Spiss vinkel    f) Spiss vinkel

A 62

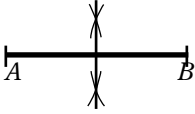

A 63

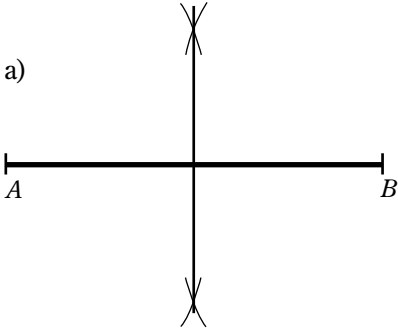

A 64

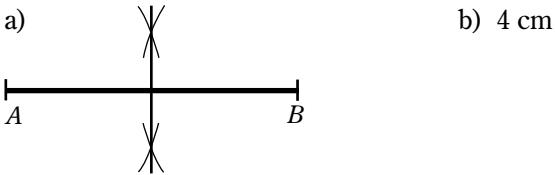

A 65

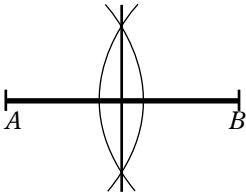

A 66

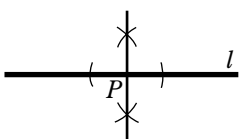

A 67

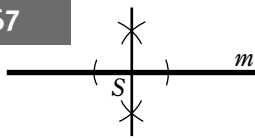

A 68

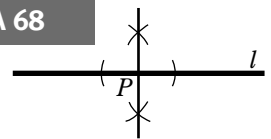

A 69

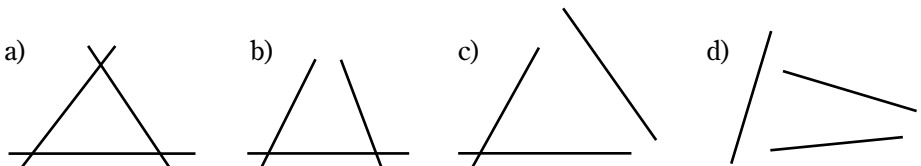

A 70

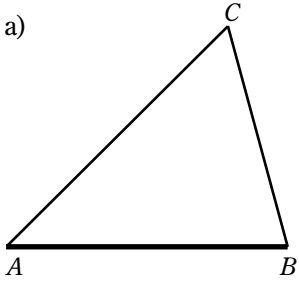

$\angle C = 60^\circ, \angle A + \angle B + \angle C = 180^\circ$

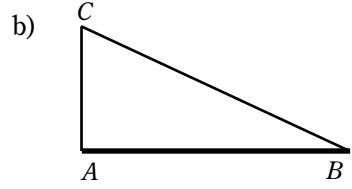

$\angle C = 55^\circ, \angle A + \angle B + \angle C = 180^\circ$

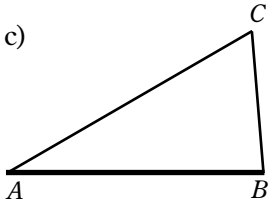

$\angle C = 65^\circ$

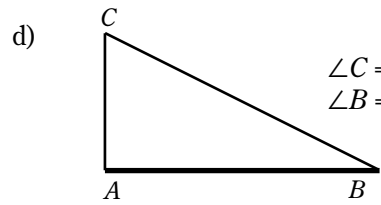

$\angle C = 65^\circ$   
 $\angle B = 25^\circ$

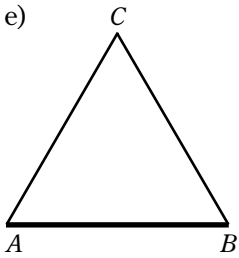

$AC = BC = 6,5 \text{ cm}, \angle C = 60^\circ$

A 71

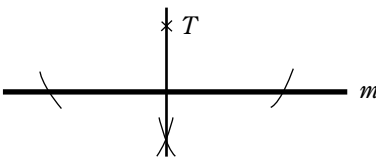

A 72

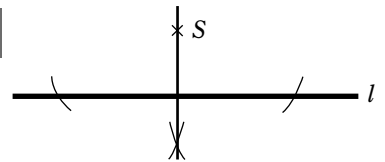

A 73

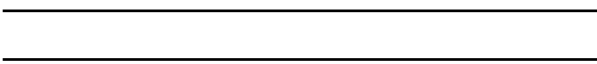

**A 75**

a)

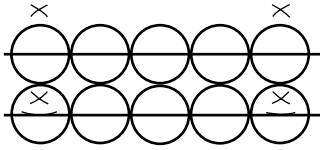

b)

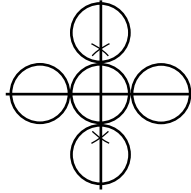

c)

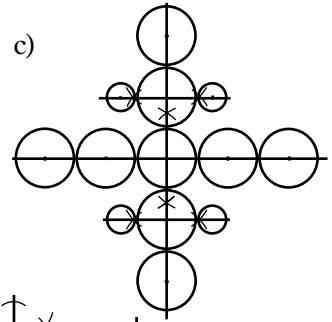

d)

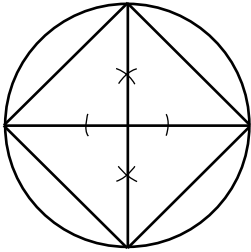

e)

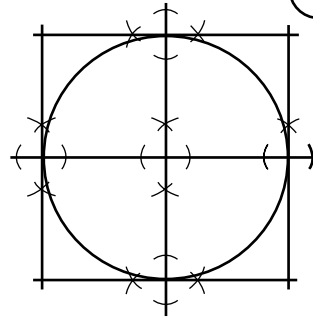

f)

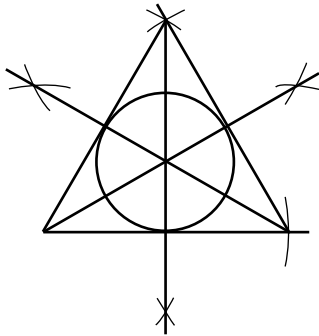

g)

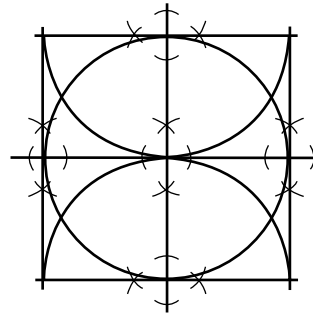
**A 76**a)  $30^\circ$ ,  $45^\circ$  og  $105^\circ$ 

b) spiss vinkel, spiss vinkel og stump vinkel

c)  $15^\circ$ ,  $22,5^\circ$ ,  $52,5^\circ$ **A 77**

Når man tegner en vinkel, kan man benytte gradskive for å finne størrelsen på vinklene. Når man konstruerer en vinkel, kan man bare benytte passer og linjal./ Når ein teiknar ein vinkel, kan ein nytte gradskive for å finne storleiken på vinklane. Når ein konstruerer ein vinkel, kan ein berre nytte passsar og linjal.

A 78

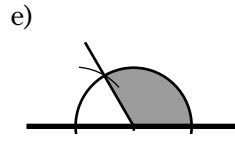
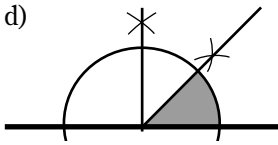
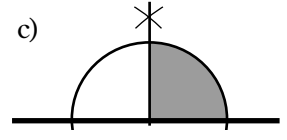
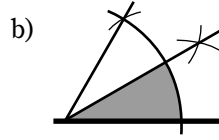
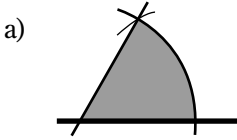

A 79

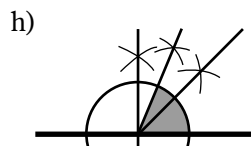
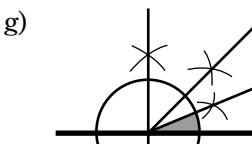
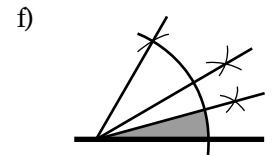
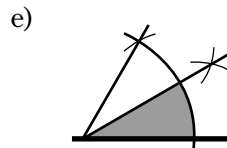
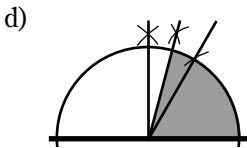
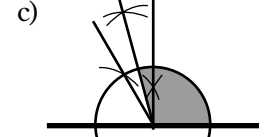
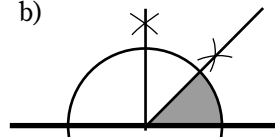
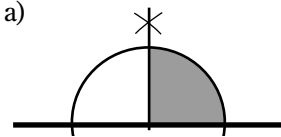

A 80

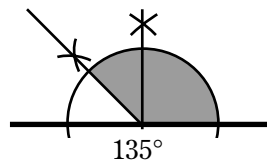
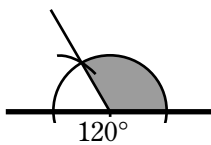
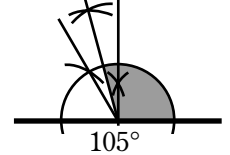
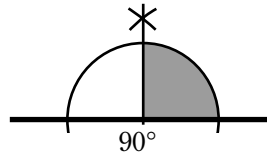
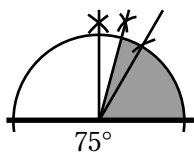
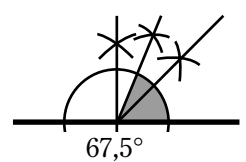
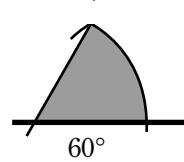
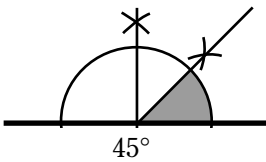
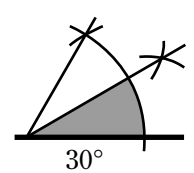
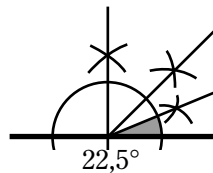
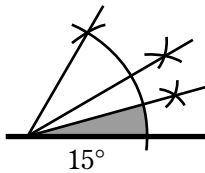

**A 81**

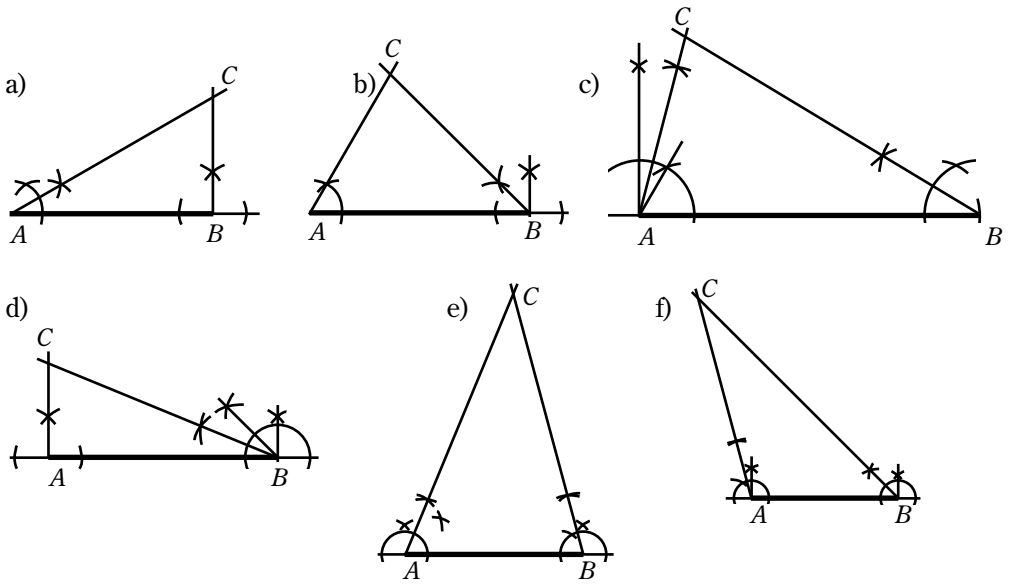

- g)  $180^\circ$       h) a)  $60^\circ$       b)  $75^\circ$       c)  $75^\circ$   
 d)  $67,5^\circ$       e)  $37,5^\circ$       f)  $30^\circ$

**A 82**

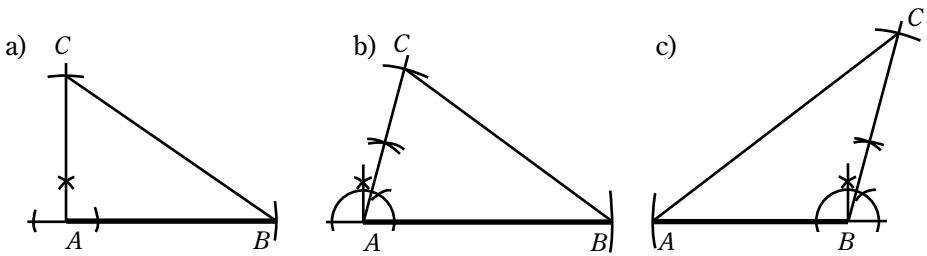

**A 83**

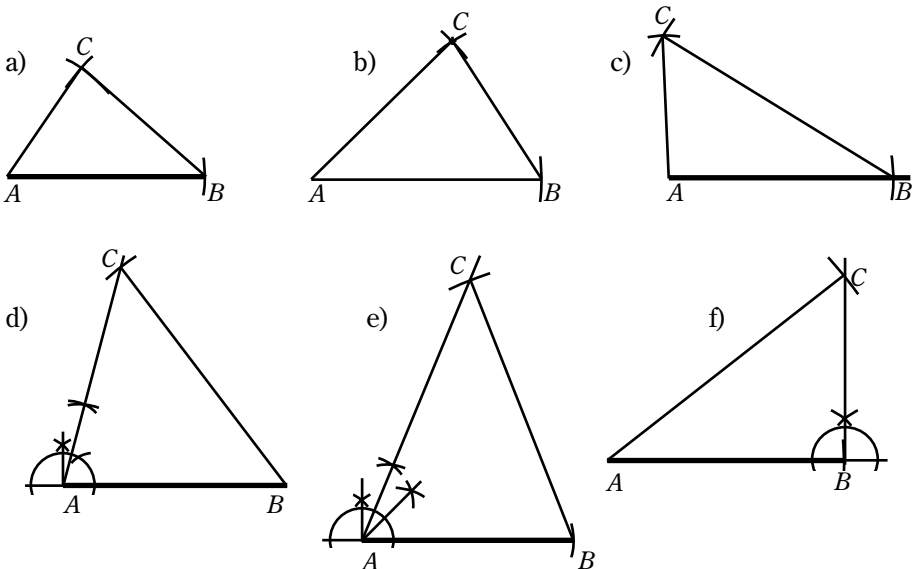

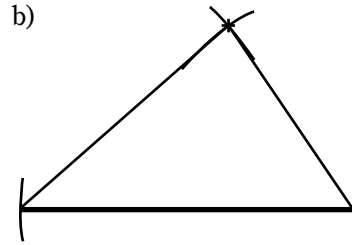
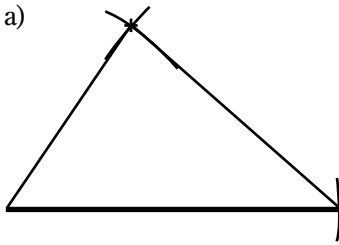
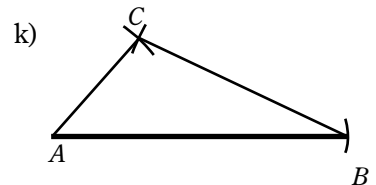
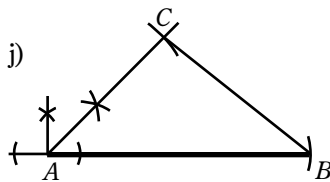
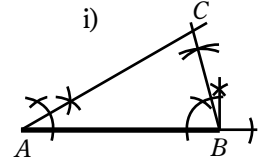
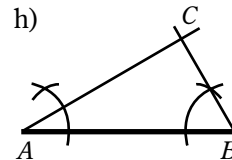
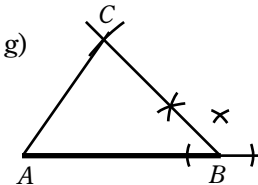
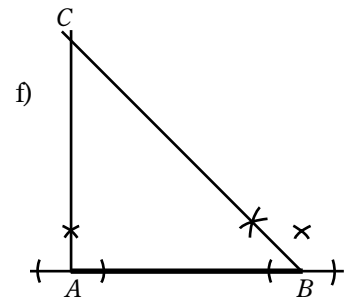
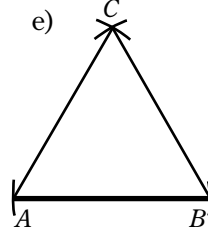
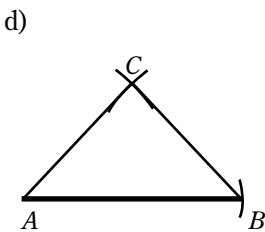
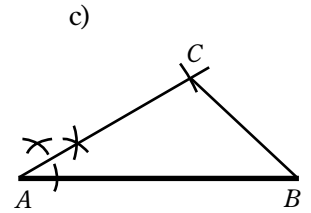
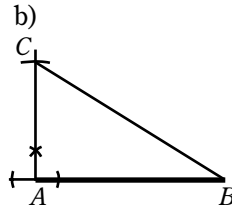
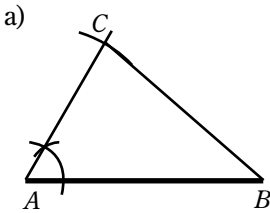

**A 84****A 85****A 86**

- En av vinklene må ha  $90^\circ$ ./Ein av vinklane må ha  $90^\circ$ .
- Like lange sider, og alle vinklene er  $60^\circ$ ./ Like lange sider, og alle vinklene er  $60^\circ$ .
- To av sidene er like lange.
- To av sidene er like lange, og vinkelen som knytter disse to sidene sammen er  $90^\circ$ ./To av sidene er like lange, og vinkelen som knytter disse to sidene saman er  $90^\circ$ .

**A 87**

- a) Rettvinklet trekant/Rettvinkla trekant  
 b) Rettvinklet trekant/Rettvinkla trekant  
 c) Likesidet trekant/Likesida trekant  
 d) Likebeint trekant  
 e) Rettvinklet, likebeint trekant./Rettvinkla, likebeint trekant.  
 f) Likebeint trekant

**A 88**

180°

**A 89**

a)

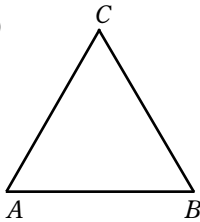

b)

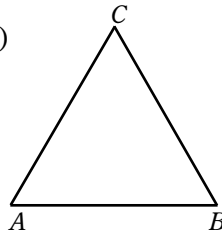

c)

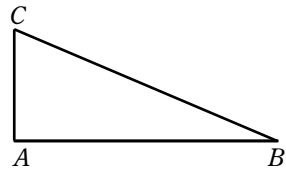

d)

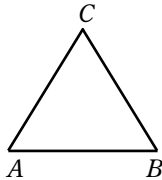

e)

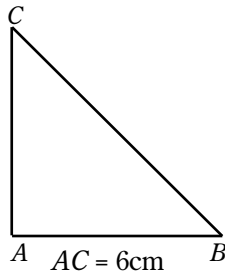

f)

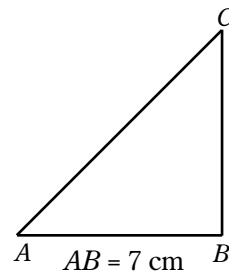
**A 90**

80°

**A 91**

60°

**A 92**

90°, 45° og 45°

**A 93** $\angle A = \angle B = 70^\circ$

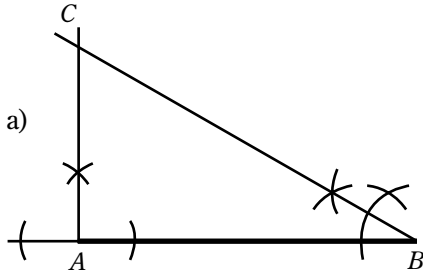
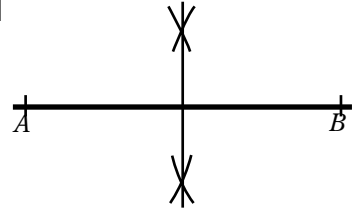
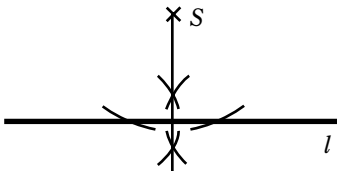
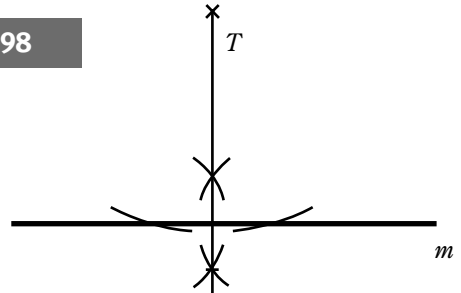
**A 94**a)   
 b) Rettvinklet trekant/Rettvinkla trekant**A 96****A 97****A 98****GUL****A 103**

Tor er 182 cm, og Line er 169 cm

**A 104**a)  $0,03 \text{ m} = 0,3 \text{ dm} = 3 \text{ cm} = 30 \text{ mm}$ b)  $0,089 \text{ m} = 0,89 \text{ dm} = 8,9 \text{ cm} = 89 \text{ mm}$ c)  $0,059 \text{ m} = 0,59 \text{ dm} = 5,9 \text{ cm} = 59 \text{ mm}$ **A 105** $47 \text{ m} = 470 \text{ dm} = 4700 \text{ cm} = 47\,000 \text{ mm}$ **A 106** $8,91 \text{ m} = 89,1 \text{ dm} = 891 \text{ cm} = 8\,910 \text{ mm}$ **A 107**a)  $0,04 \text{ m}$ b)  $0,057 \text{ m}$ c)  $0,0069 \text{ m}$ d)  $0,009 \text{ m}$ **A 108** $12,192 \text{ m}$ **A 109** $5,34 \text{ dm}$ **A 110**a)  $45^\circ$ b)  $120^\circ$ c)  $18^\circ$ d)  $98^\circ$

A 111

- a)  $120^\circ$     b)  $45^\circ$     c)  $72^\circ$

A 112

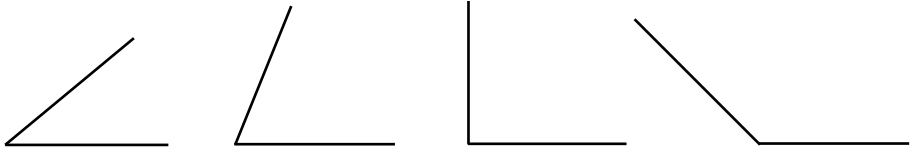

- a) Spiss vinkel    b) Spiss vinkel    c) Rett vinkel    d) Stump vinkel

A 113

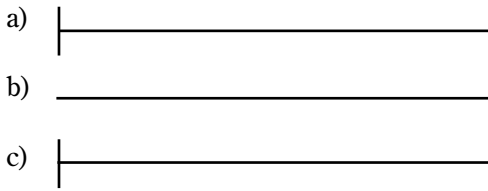

- a)  
b)  
c)

A 114

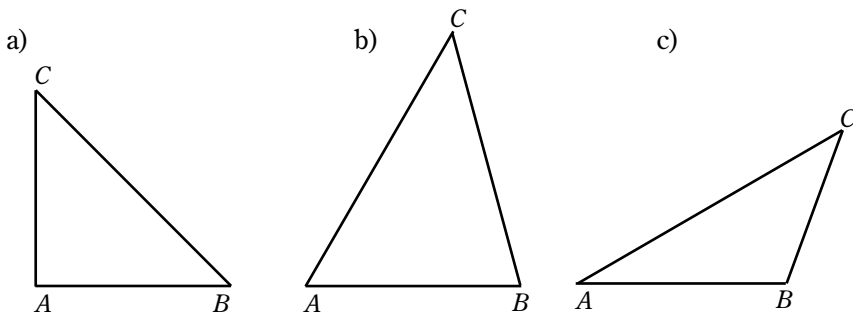

- d) Vinkelsummen i alle trekanter er  $180^\circ$

A 115

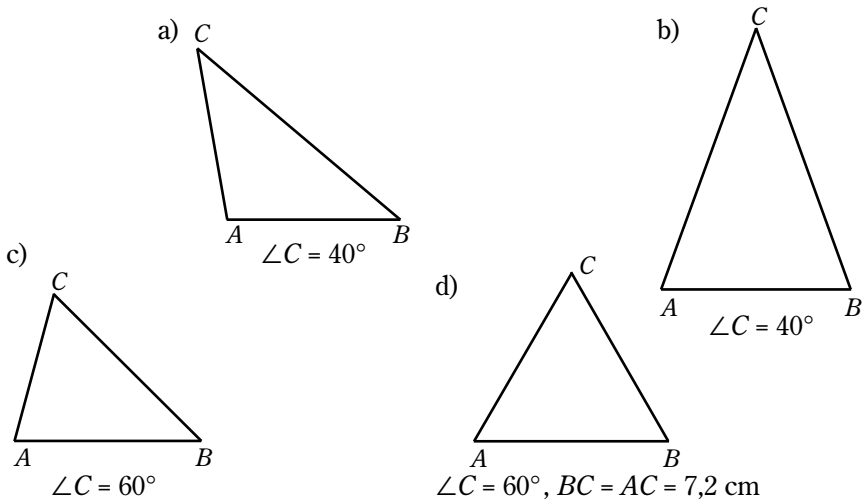

A 116

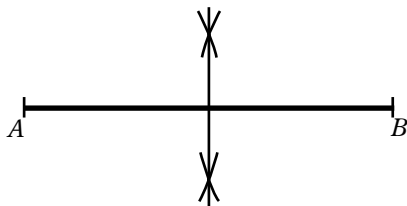

A 117

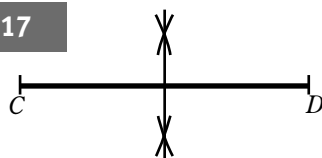

A 118

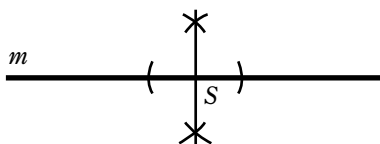

A 119

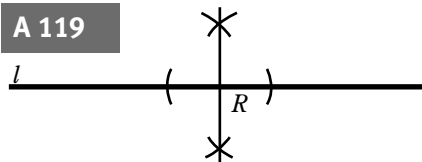

A 120

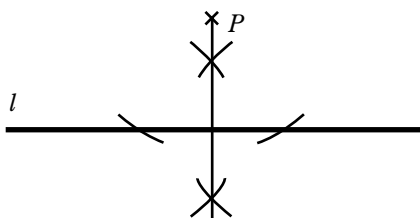

A 121

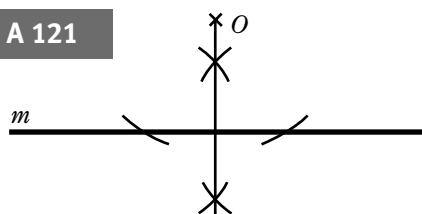

A 122

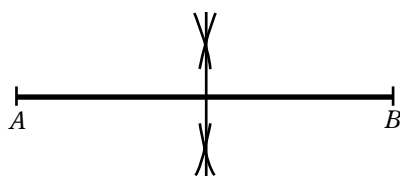

A 123

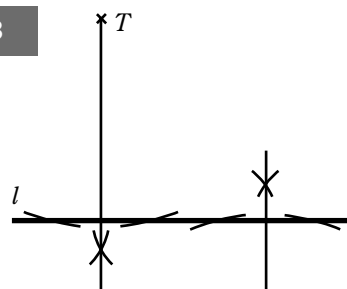

A 124

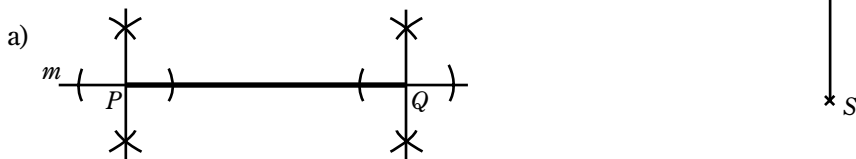

b) De to normalene vil aldri skjære hverandre, fordi de er parallelle med hverandre./Dei to normalane vil aldri skjære kvarandre, fordi dei er parallelle med kvarandre.

A 125

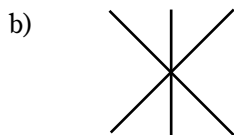
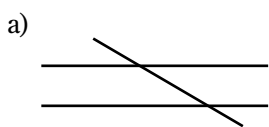

d) Parallele linjer

A 126

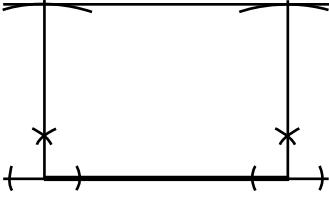

A 127

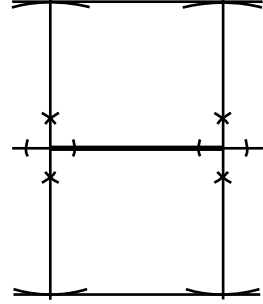

A 128

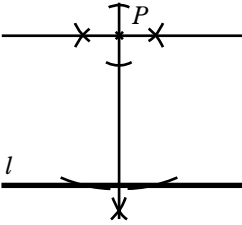

A 129

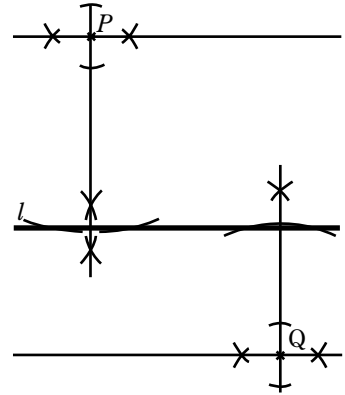

A 130

a)

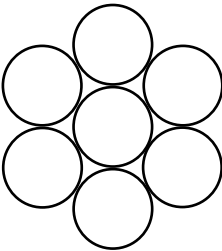

b)

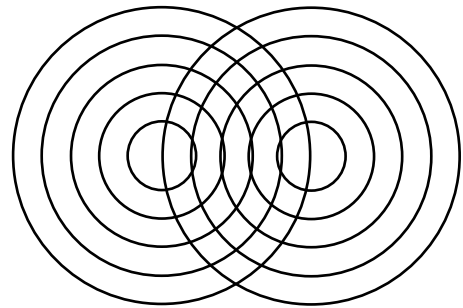

c)

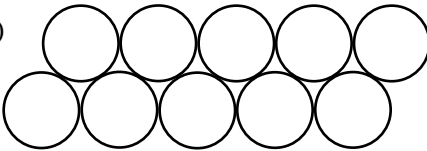

d)

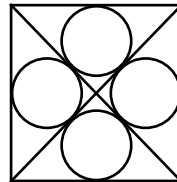

A 131

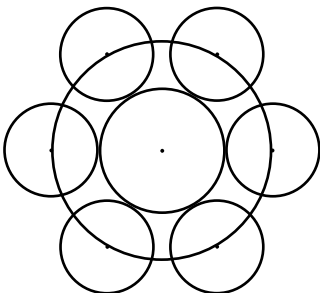

A 132

a, b)

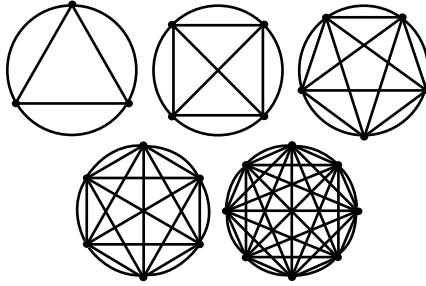

- c) Når man øker antall punkter med ett, vil antall linjer som kan trekkes mellom punktene, øke med like mange linjer som det var punkter før økningen./Når ein aukar talet på punkt med eit, vil talet på linjer som ein kan trekke mellom punkta, auke med like mange linjer som det var punkt før auken.

A 133

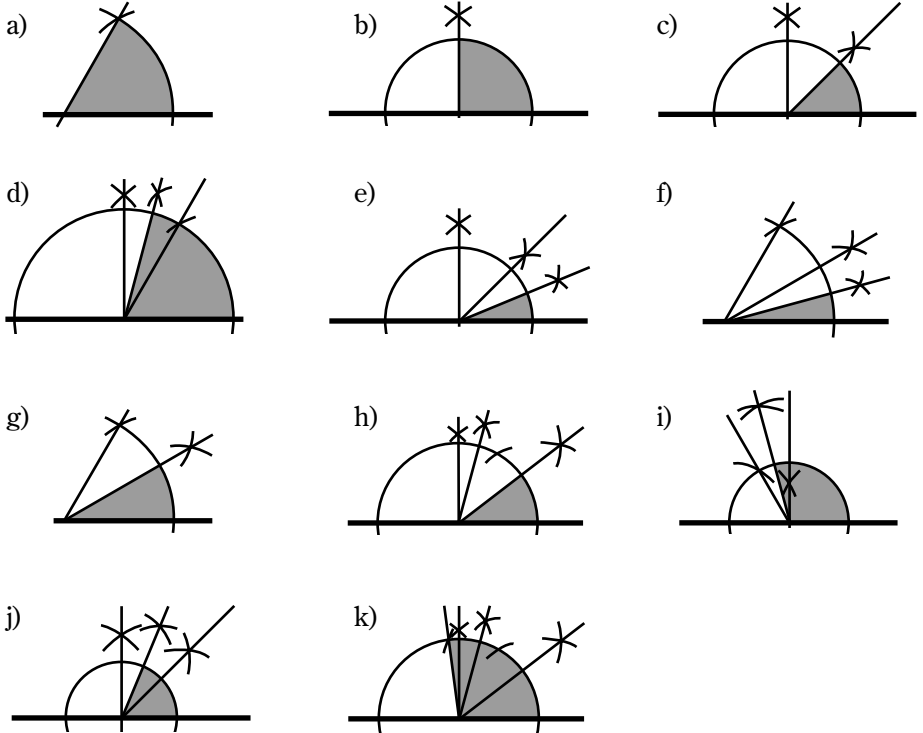

A 134

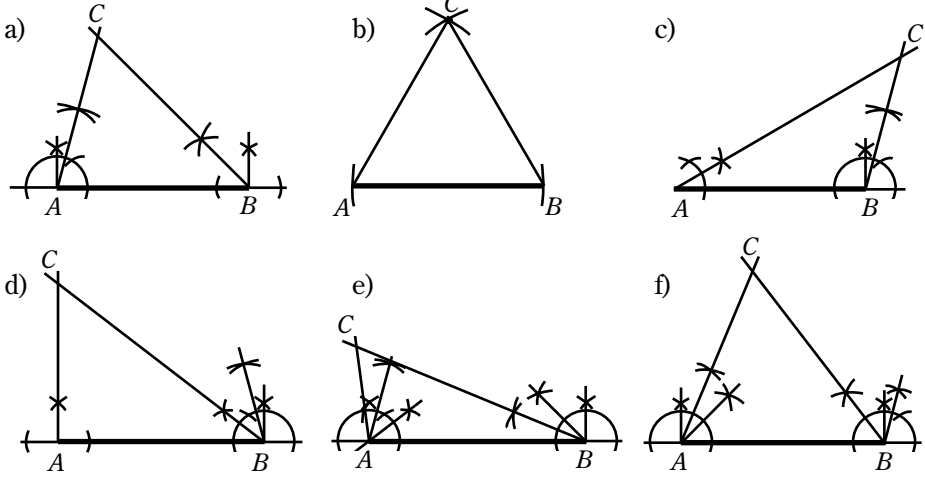

A 135

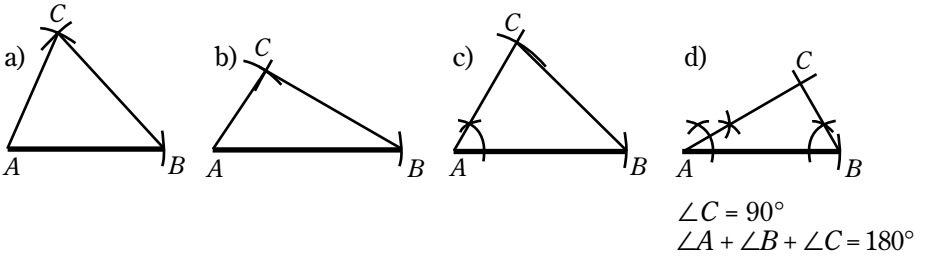

A 136

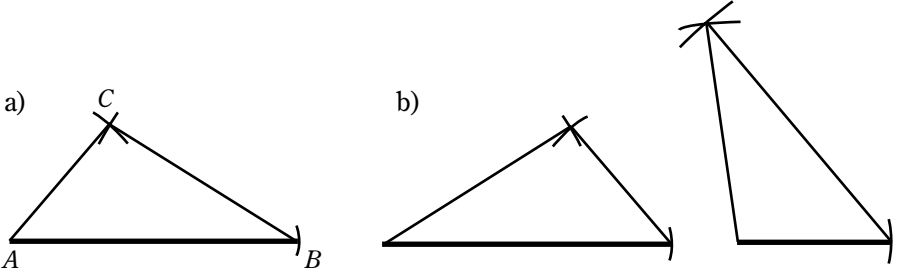

A 137

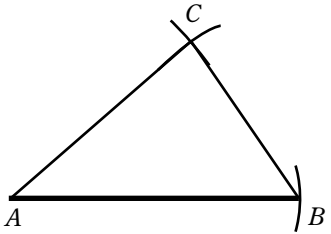

A 138

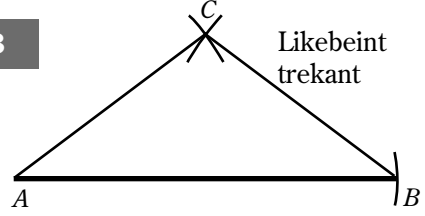

A 139

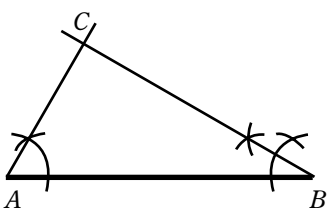

A 140

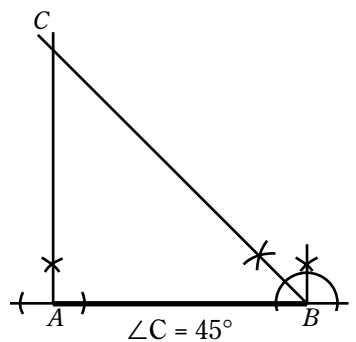



A 141

- a) Rettvinklet trekant/Rettvinkla trekant
- b) Likesidet trekant/Likesida trekant
- c) Rettvinklet trekant/Rettvinkla trekant
- d) Rettvinklet, likebeint trekant/Rettvinkla, likebeint trekant,  
 $\angle A = 45^\circ$  og  $\angle C = 45^\circ$
- e) Rettvinklet, likebeint trekant/Rettvinkla, likebeint trekant,  $\angle C = 90^\circ$
- f) Likesidet trekant/Likesida trekant,  $\angle A = \angle B = \angle C = 60^\circ$

A 142

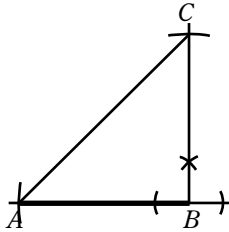

A 143

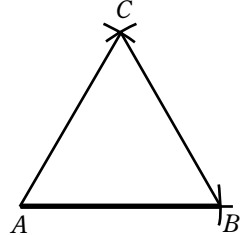

A 144

Nei, en rettvinklet trekant har en vinkel som er  $90^\circ$ , mens i likesidete trekanter er alle vinklene  $60^\circ$ ./Nei, ein rettvingla trekant har ein vinkel som er  $90^\circ$ , medan i likesida trekantar er alle vinklane  $60^\circ$ .

A 145

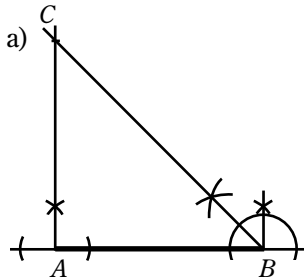

- b)  $\angle A = 90^\circ$
- c)  $AC = 6 \text{ cm}$
- d) Rettvinklet, likebeinet trekant./Rettvinkla, likebeinet trekant.

A 146

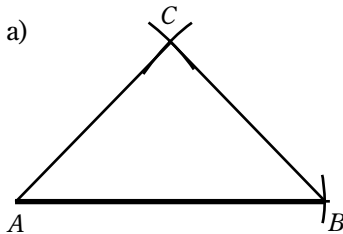

- b) Likebeint trekant

A 147

- a) 8
- b) 4 rettvinklet trekanter, 2 likebeint trekanter og 2 ordinære trekanter./  
4 rettvingla trekantar, 2 likebeint trekantar og 2 ordinære trekantar.

A 148

Ved sykkelstativet, og i granskogen.

A 149

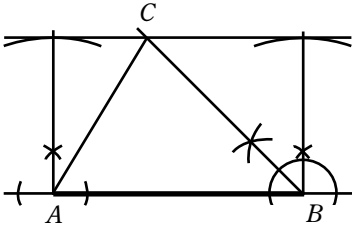

A 150

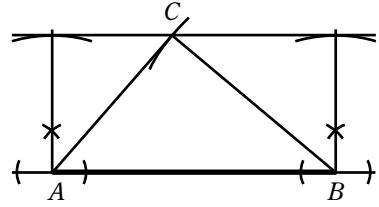

A 151

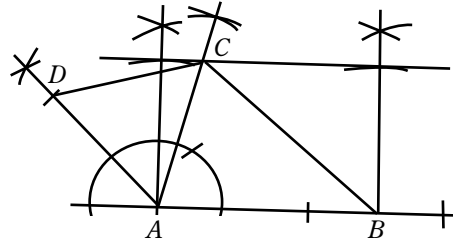
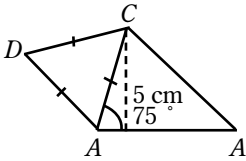

A 152

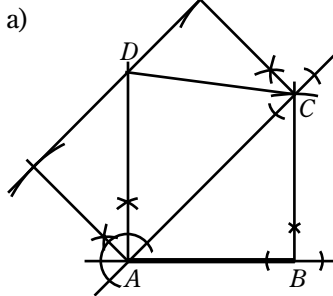

b)  $\angle BAC = \angle BCA = 45^\circ$  siden  $\angle B = 90^\circ$  og  $AB = BC$

c) En rettvinklet, likebeint trekant./  
Ein rettvinkla, likebeint trekant.

A 153

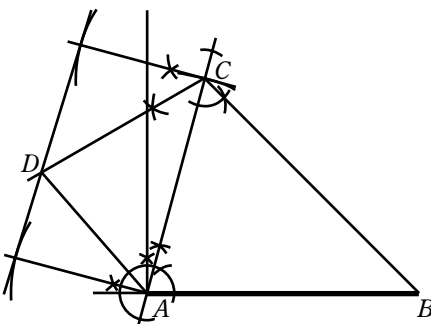

A 154

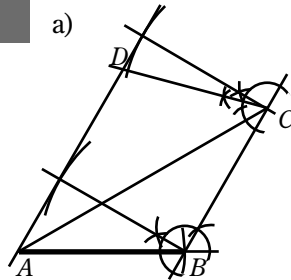

b)  $ABC$  er likebeint trekant

## RØD/RAUD

**A 160**

Vivi	Sanya	Kine	Solveig	Guri
474 cm	481 cm	485 cm	494 cm	497 cm

**A 163**

- a) 14,63 m                      b) 4,272 dm                      c) 25 fot

**A 164**

- a) 1 yard = 0,9144 m      b) 1 mile = 1609 m

**A 166**

a)

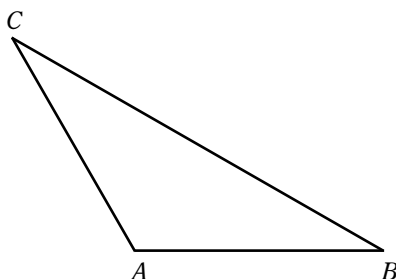

b)

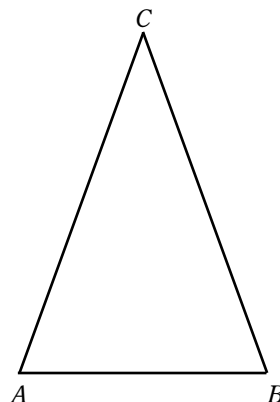

c)

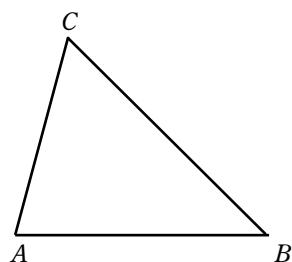

d)

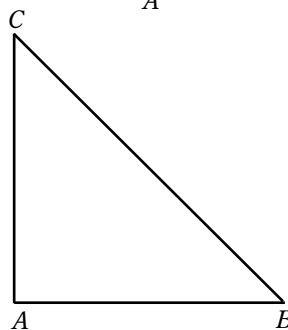

**A 167**

30°, 60° og 90°

**A 168**

40°, 70° og 70°

**A 169**

- a) 180°                      b) 180°                      c) 180°

**A 170**

- a) 360°                      b) 360°                      c) 360°

**A 171**

Alle trekanter har vinkelsum lik 180°, og alle firkanter har vinkelsum lik 360°./  
Alle trekantar har vinkelsum lik 180°, og alle firkantar har vinkelsum lik 360°.

**A 172**

40°, 60° og 80°

**A 173**

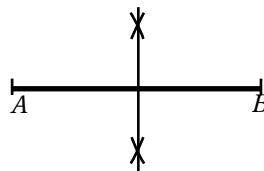

A 174

a)  $30^\circ$

b)  $73^\circ$

c)  $132^\circ$

d)  $80^\circ$

A 175

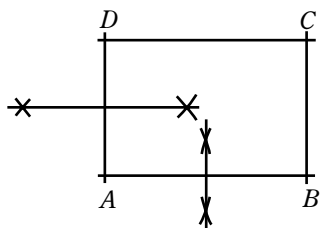

A 176

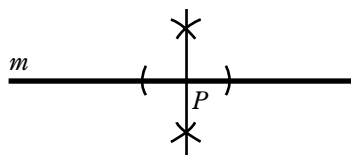

A 177

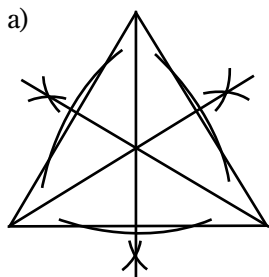

- b) De tre midtnormalene skjærer hverandre i ett og samme punkt./  
 Dei tre midtnormalane skjær kvarandre i eitt og same punkt.

Forslag

- c) Midtnormalene i en trekant treffer alltid i samme punkt./M...

A 178

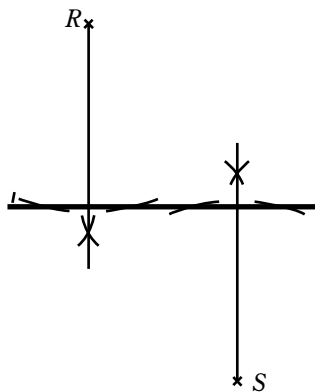

A 179

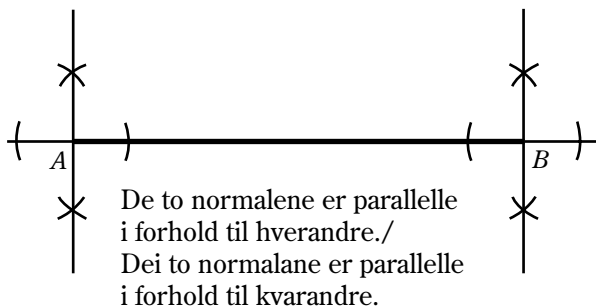

A 180

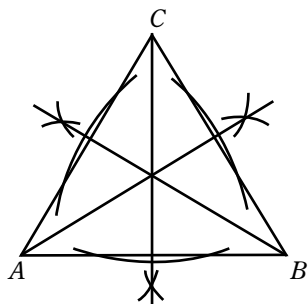

A 181

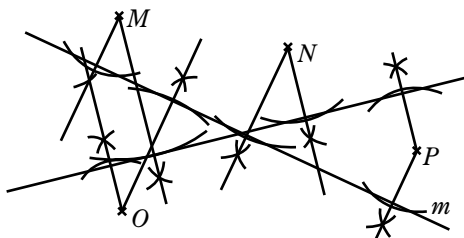

A 182

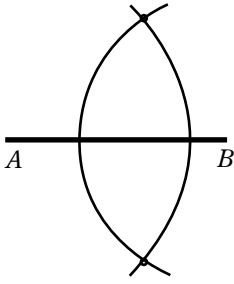

A 183

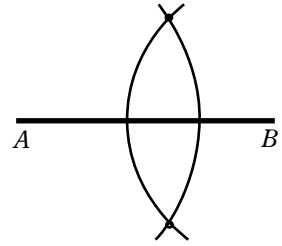

A 184

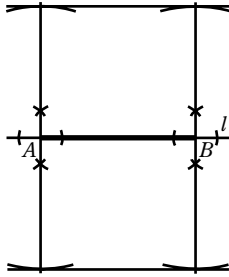

A 185

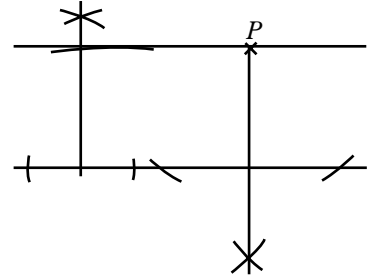

A 186

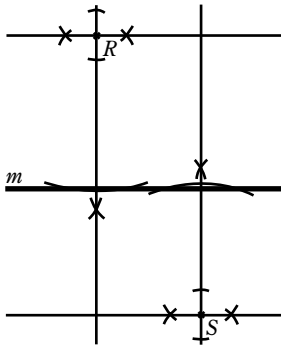

A 187

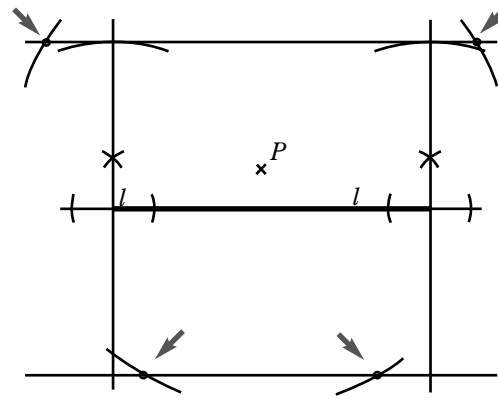

A 188

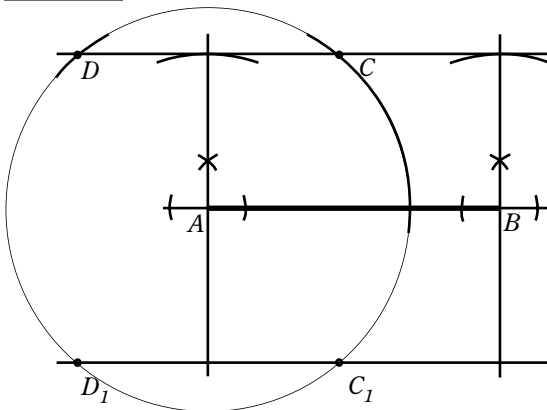

A 189

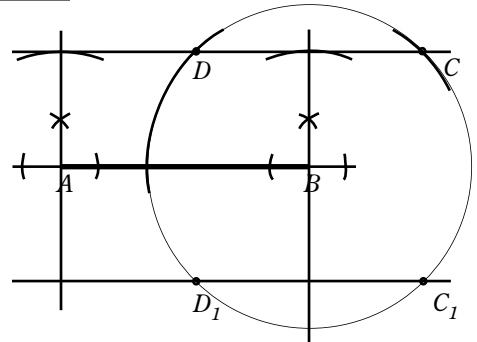

A 190

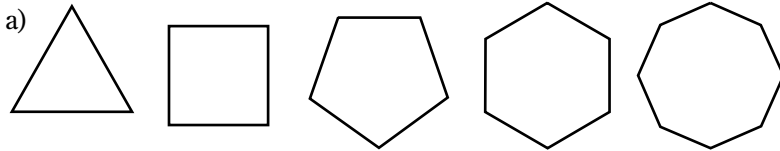

b) Trekanter har vinkelsum på  $180^\circ$ , firkanter har vinkelsum på  $360^\circ$ , femkanter har vinkelsum på  $540^\circ$ , sekskanter har vinkelsum på  $720^\circ$  og åttekanter har vinkelsum på  $1080^\circ$ . / Trekantar har vinkelsum på  $180^\circ$ , firkantar har vinkelsum på  $360^\circ$ , femkantar har vinkelsum på  $540^\circ$ , sekskantar har vinkelsum på  $720^\circ$  og åttekantar har vinkelsum på  $1080^\circ$ .

c) Antall sider, minus to, multipliser med  $180^\circ$ . /  
Talet på sider, minus to, multipliser med  $180^\circ$ .

A 191

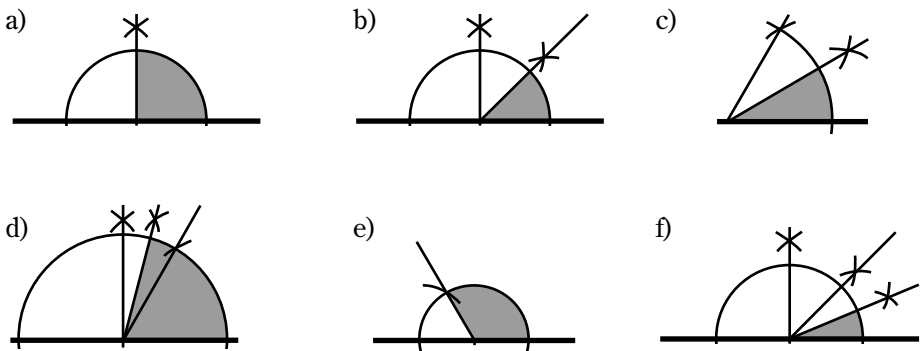

A 192

Når man tegner en vinkel, benytter man linjal og gradskive.

Når man konstruerer en vinkel, kan man bare benytte passer og linjal. /

Når ein teiknar ein vinkel, nyttar ein linjal og gradskive.

Når ein konstruerer ein vinkel, kan ein berre nytte passar og linjal.

A 193

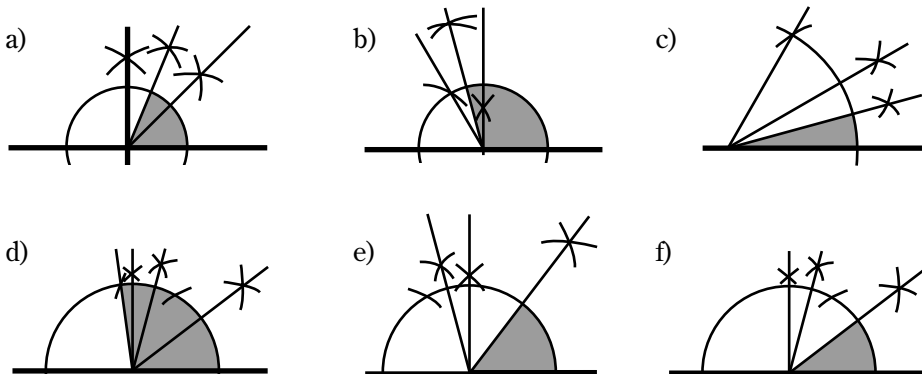

A 194

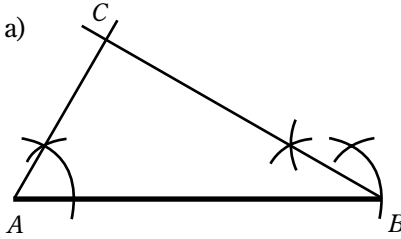

b)  $\angle C = 90^\circ$

c) Rettvinklet trekant/Rettvinkla trekant

A 195

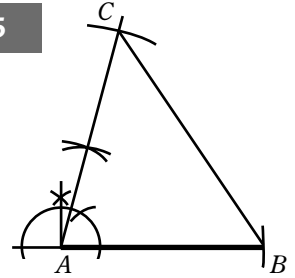

A 196

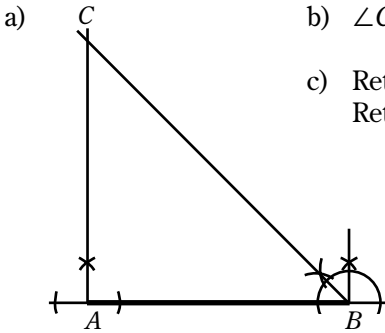

b)  $\angle C = 45^\circ$

c) Rettvinklet, likebeint trekant./  
Rettvinkla, likebeint trekant.

A 197

- a) Rettvinklet trekant./  
Rettvinkla trekant.
- c) Likebeint trekant
- e) Likesidet trekant./  
Likesida trekant.

- b) Likesidet trekant./  
Likesidet trekant.
- d) Rettvinklet, likebeint trekant./  
Rettvinkla, likebeint trekant.
- f) Rettvinklet, likebeint trekant  
Rettvinkla, likebeint trekant

A 198

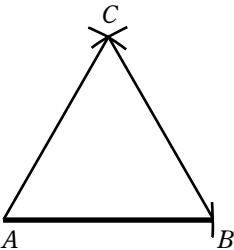

A 199

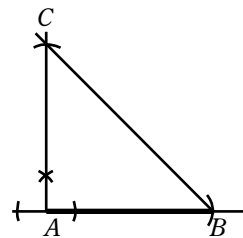

A 200

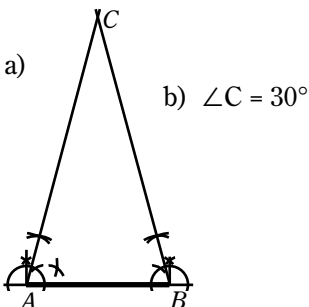

A 201

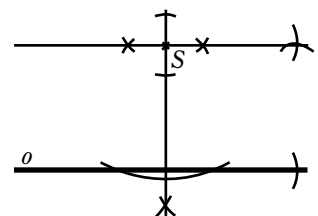

A 202

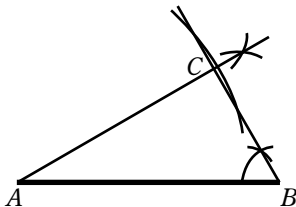

A 203

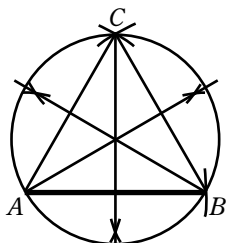

c) Midtnormalene har skjæringspunkt midt i trekanten./Midtnormalane har skjæringspunkt midt i trekanten.

e) En passerstrek med denne radien lager en sirkel rundt hjørnene av trekanten./Ein passarstrek med denne radien lagar ein sirkel kring hjørna av trekanten.

A 204

I en likesidet trekant er alle vinklene  $60^\circ$  og kan derfor ikke være en rettvinklet trekant.

A 205

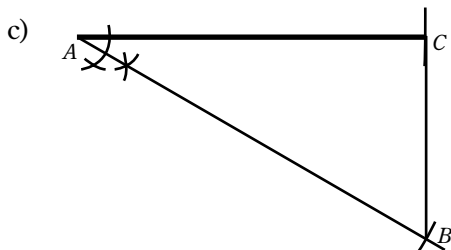
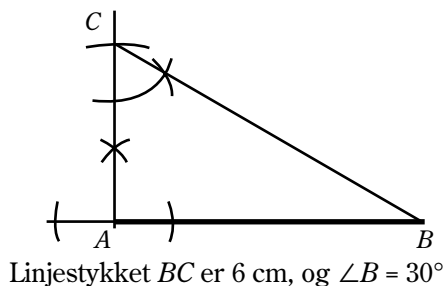
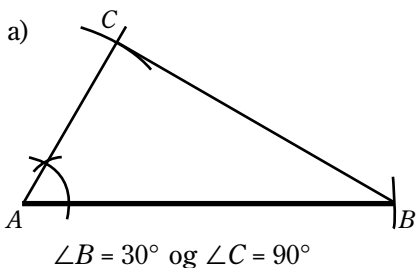

Linjestykket  $BC$  er 6 cm,  $\angle B = 60^\circ$

d) Vinklene er:  
Vinklane er:  
 $30^\circ$ ,  $60^\circ$  og  $90^\circ$

e) Den korte kateten er halvparten så lang som hypotenusen.



A 206

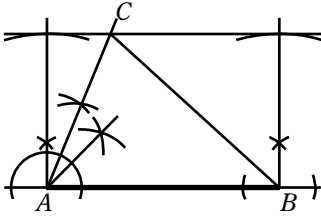

A 207

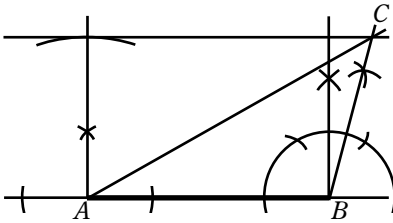

A 208

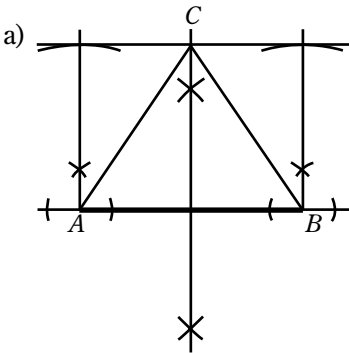

A 209

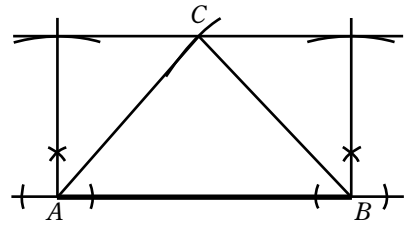

b) Likebeint trekant.

A 210

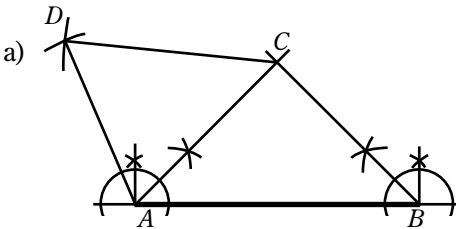

b)  $90^\circ$

c) Rettvinklet, likebeint trekant./  
Rettvinkla, likebeint trekant.

A 211

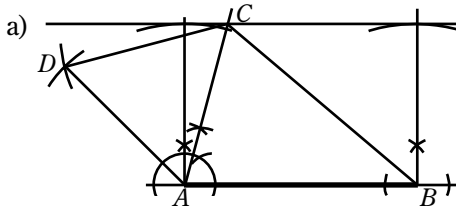

A 212

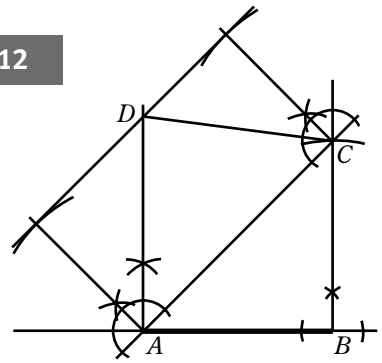

- b)  $\angle BAC = \angle ACB = 45^\circ$ ,  
fordi  $AB = BC$  og  $\angle B = 90^\circ$   
c) Rettvinklet, likebeint trekant./  
Rettvinkla, likebeint trekant.

A 213

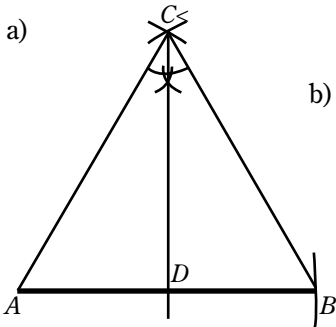

- b)  $\angle ACD = \angle BCD = 30^\circ$ ,  $\angle ADC = \angle BDC = 90^\circ$

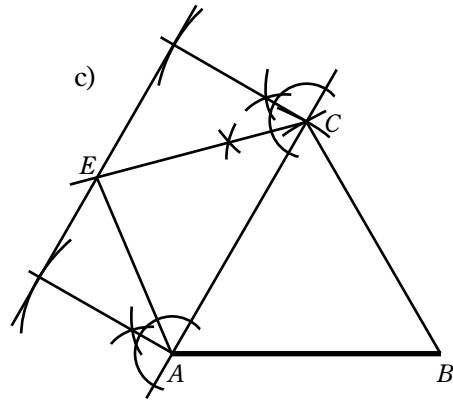

A 214

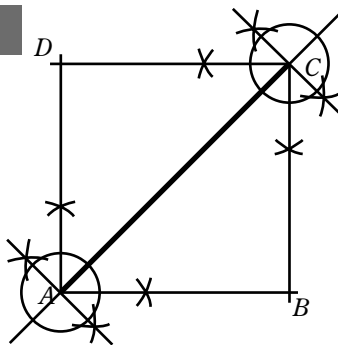

A 215

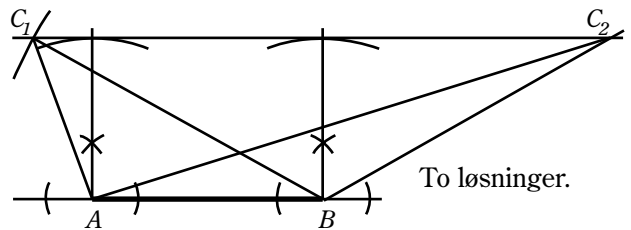

A 216

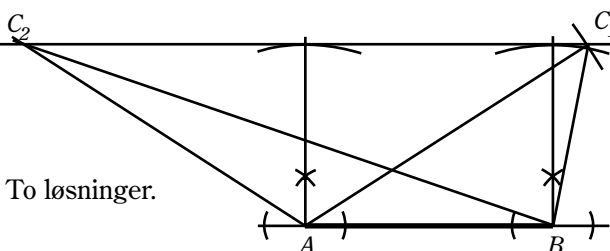

A 217

a)

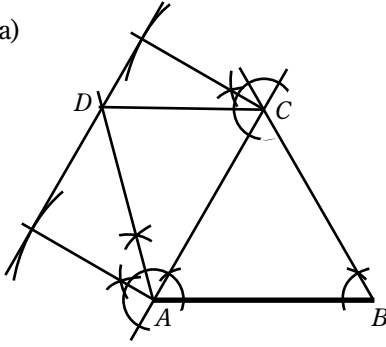

b)  $AC = BC = 7$  cm

c)  $\angle ACB = 60^\circ$ . Likesidet trekant./  
Likesida trekant.

A 218

a)

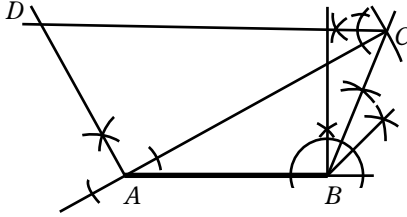

b) Rettvinklet trekant./  
Rettvinkla trekant.

A 219

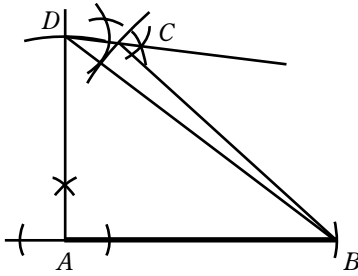

A 220

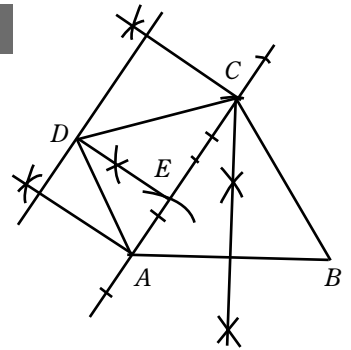

A 221

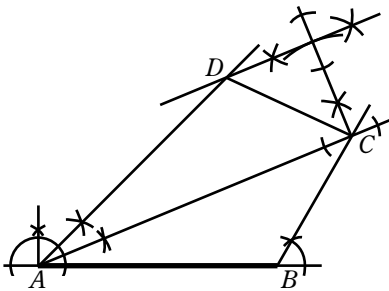

A 222

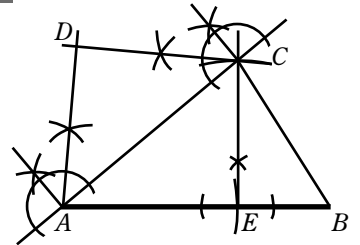

A 223

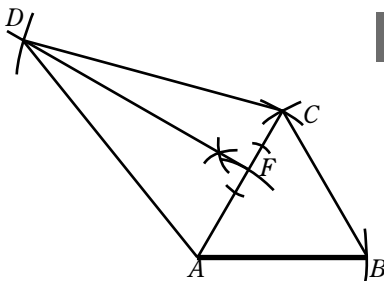

A 224

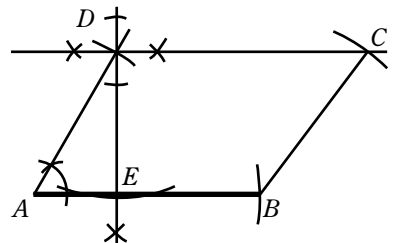

# PRØV DEG SELV/PRØV DEG SJØLV

PA 1

- a) Linje    b) Linjestykke    c) Stråle

PA 2

- a) Toppunkt    b) Venstre vinkelbein  
 c) Størrelse på vinkelen i grader/  
 Storleiken på vinkelen i gradar    d) Høyre vinkelbein/  
 Høyre vinkelbein

PA 3

- a) 5 m    b) 1200 m    c) 0,035 m  
 d) 0,012 m    e) 0,32 m    f) 0,00012 m

PA 4

- a)  $30^\circ$ , spiss vinkel    b)  $90^\circ$ , rett vinkel    c)  $95^\circ$ , stump vinkel

PA 5

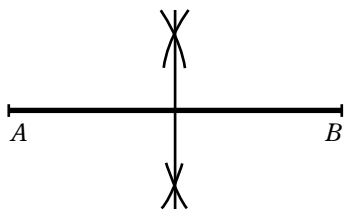

PA 6

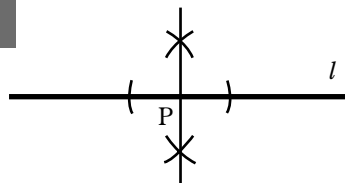

PA 7

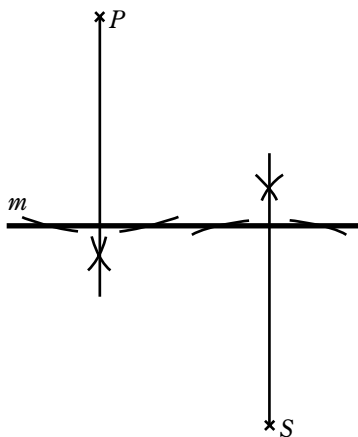

PA 8

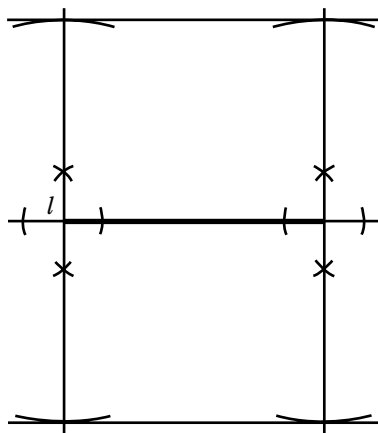

PA 9

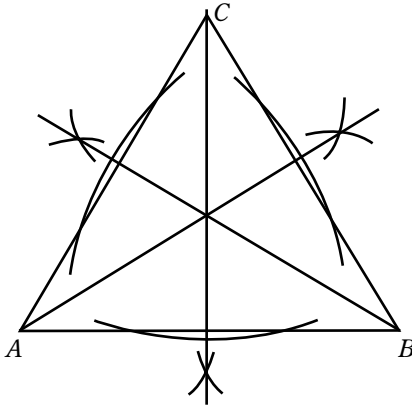

PA 10

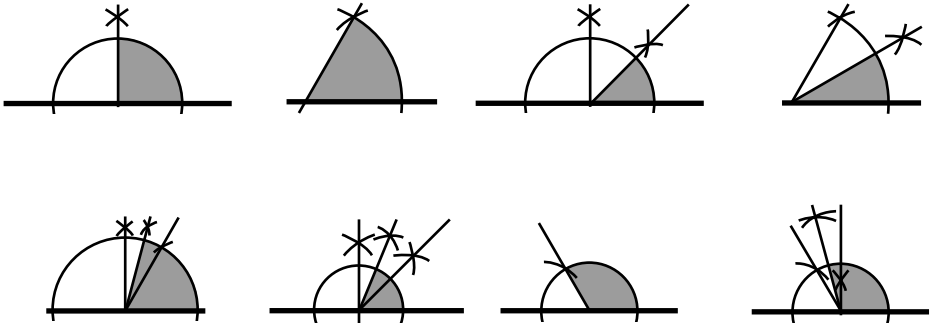

PA 11

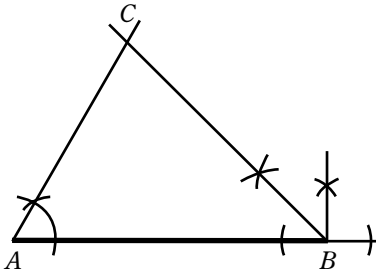

PA 12

$\angle C = 70^\circ$

PA 13

$\angle BAC, \angle CAD$  og  $\angle ACB$

PA 14

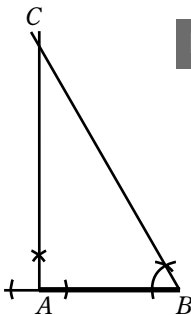

PA 15

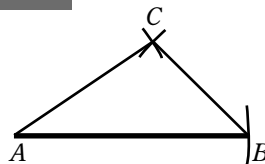

PA 16

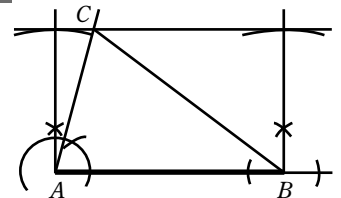

PA 17

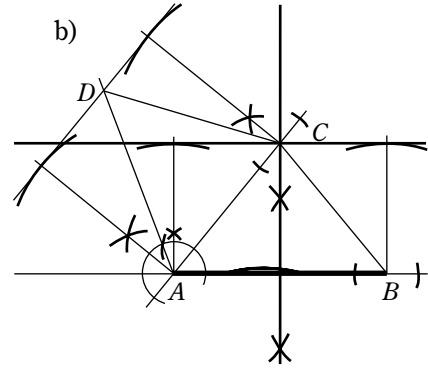
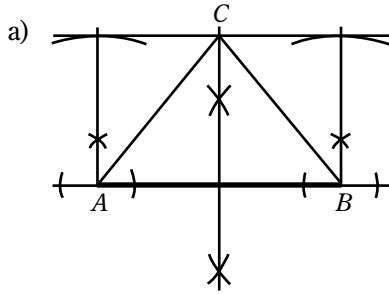

## FYLKESOPPGAVE TROMS/ FYLKESOPPGAVE TROMS

FA 1

- a) 62 558 innbyggere/  
innbyggjarar      b) 152 740 innbyggere/  
innbyggjarar      c) 2 437 innbyggere/  
innbyggjarar

FA 2

820 m

FA 3

- a) 4 280 mm      b) 71,3 mm/døgn      c) 10,0 cm

FA 4

75,8 °C

FA 4

- a) 139 år i 2007s      b) 36,3 m

FA 6

946 000 kr

FA 7

1 488 timer/timar

FA 8

- c) Tromsø



**B 18**

- |       |        |        |
|-------|--------|--------|
| a) 40 | b) 20  | c) 60  |
| d) 60 | e) 120 | f) 410 |

**B 19**

- |       |       |        |
|-------|-------|--------|
| a) 12 | b) 24 | c) 16  |
| d) 30 | e) 80 | f) 135 |
| g) 28 | h) 1  |        |

**B 20**

- |       |      |      |
|-------|------|------|
| a) 10 | b) 3 | c) 6 |
| d) 5  | e) 3 | f) 6 |
| g) 5  | h) 2 |      |

**B 21**

8,80 kroner

**B 22** $3 + 3 = 6$ **B 23**

- |       |       |       |
|-------|-------|-------|
| a) 5  | b) 9  | c) 6  |
| d) 17 | e) 21 | f) 29 |
| g) 20 | h) 19 | i) 41 |
| j) 42 | k) 2  | l) 4  |
| m) 0  | n) 16 | o) 6  |

**B 24**

- |          |           |        |
|----------|-----------|--------|
| a) 356   | b) 239    | c) 100 |
| d) 5 264 | e) 704    | f) 670 |
| g) 7 071 | h) 54 106 |        |

**B 25**

- |           |           |           |
|-----------|-----------|-----------|
| a) 22     | b) 222    | c) 3 651  |
| d) 711    | e) 775    | f) 83 063 |
| g) 25 257 | h) 23 208 |           |



**B 26**

- a) 36                      b) 669                      c) 168                      d) 28 990

**B 27**

- a) 732                      b) 19 712                      c) 8 255                      d) 75 848

**B 28**

- a) 21                      b) 7                      c) 81                      d) 82  
e) 91                      f) 51

**B 29**

- a) 2 340                      b) 1 281                      c) 4 175

**B 30**

- a) 37                      b) 36                      c) 39                      d) 453

**B 31**

- a) 4 : 2                      b) 36 : 6                      c) 16 : 4                      d) 1 : 1  
e) 9 : 3                      f) 49 : 7                      g) 64 : 8                      h) 81 : 9  
i) 100 : 10

**B 32**

- a) 2, 4, 6, 8, 10, 12, 14, 16, 18, 20, 22, 24, 26, 28, 30  
b) Partall er hele tall, som er delelige med 2. Partall slutter på 0, 2, 4, 6, 8./  
Partal er heile tal, som er delelege med 2. Partall sluttar på 0, 2, 4, 6, 8.  
c)  $4 + 8 = 12$                        $12 + 14 = 26$                        $60 + 62 = 122$

**B 33**

- a) ja                      b) partall/partal                      c) oddetall/oddetal  
d) partall/partal                      e) oddetall/oddetal

**B 34**

- a) 83, Oddetall/Oddetal                      b) 1405, Oddetall/Oddetal  
c) 2, Partall/Partal                      d) 24, Partall/Partal  
e) 21, Oddetall/Oddetal                      f) 25, Oddetall/Oddetal

**B 35**

- 29, 31, 59, 61

**B 36**

a)  $12 = 3 \cdot 2 \cdot 2$

b) Riktig/Rett

c)  $42 = 7 \cdot 3 \cdot 2$

d) Riktig/Rett

**B 37**

a)  $9 = 3 \cdot 3$

b)  $22 = 11 \cdot 2$

c)  $36 = 3 \cdot 3 \cdot 2 \cdot 2$

d)  $14 = 7 \cdot 2$

e)  $56 = 7 \cdot 2 \cdot 2 \cdot 2$

f)  $72 = 3 \cdot 3 \cdot 2 \cdot 2 \cdot 2$

g)  $81 = 3 \cdot 3 \cdot 3 \cdot 3$

h)  $105 = 7 \cdot 5 \cdot 3$

i)  $125 = 5 \cdot 5 \cdot 5$

j)  $48 = 3 \cdot 2 \cdot 2 \cdot 2 \cdot 2$

k)  $162 = 3 \cdot 3 \cdot 3 \cdot 3 \cdot 2$

l)  $500 = 5 \cdot 5 \cdot 5 \cdot 2 \cdot 2$

**B 38**

a) 6,7

b) 19,8

c) 8,97

d) 4,67

e) 72,4

f) 12,12

**B 39**

a) 6,3

b) 10,44

c) 0,78

d) 6,599

e) 15,07

f) 0,2172

**B 40**

a) 0,3

b) 1,4

c) 11,1

d) 116,1

e) 1,605

f) 0,852

g) 0,0968

h) 2,368

**B 41**

a) 9,36

b) 679,9

c) 9,36

d) 515,6

**B 42**

448 kroner

**B 43**

523,20 kroner

**B 44**

14,8 kg

**B 45**

843 kroner

**B 46**

41 700 kroner

**B 47**

1 073 km

**B 48**

1 906,50 kroner

**B 49**

15 503 kroner

**B 50**

- a) 6,4                      b) 2,3                      c) 5,03                      d) 4,02  
e) 25,15                      f) 5,162

**B 51**

- a) 4                              b) 3                              c) 3                              d) 30

**B 52**

- a) 5,67                      b) 6,29                      c) 7,44                      d) 1,63

**B 53**

- a) 2 °C                      b) 0 °C                      c) -10 °C                      d) -15 °C

**B 54**

- a) -4 °C                      b) 0 °C                      c) 20 °C                      d) 27 °C

**B 55**

22 °C

**B 56**

-200 kroner

**B 57**

240 kroner

**B 58**

56 år gammel/56 år gammel

**B 59**

- a) 25 år gammel/25 år gammel                      b) 77 år gammel/77 år gammel

**B 60**

1 619 meter

**B 61**

- a)  $6 > 4$                       b)  $5 < 12$                       c)  $121 > 0$   
d)  $3 < 7$                       e)  $223 < 232$                       f)  $19 > 18,59$

**B 62**

- a)  $2 > -3$                       b)  $-6 < -3$                       c)  $-8 < 2$   
d)  $-4 > -23$                       e)  $-3 < -1$                       f)  $-8 < 0$   
g)  $-6 > -8$                       h)  $-1,3 < -1,29$                       i)  $-0,9 > -0,96$

**B 63**

- a)  $A = 12, B = 5, C = -12, D = -7, E = -1$   
b)  $A = -30, B = -140, C = -220, D = 20, E = -90$   
c)  $A = -550, B = -400, C = -750, D = -950, E = -300$

**B 64**

- a)  $A = -0,1, B = -0,9, C = 0,1, D = -1,1, E = -0,6$   
b)  $A = -0,5, B = 0,75, C = -1,25, D = -2,25, E = -1,75$   
c)  $A = -0,05, B = 0,01, C = -0,11, D = -0,09, E = -0,02$

**B 65**

- a) 19                      b) 1                      c) 2                      d) 2  
e) -2                      f) 7                      g) 0                      h) 7

**B 66**

- a) 103                      b) 40                      c) 17                      d) -46  
e) 271                      f) -2                      g) -210                      h) 14

**B 68**

- a) -2                      b) -4                      c) -5                      d) -5  
e) -3                      f) -5

**B 69**

- a) 2                      b) 1                      c) 0                      d) -1  
e) -2                      f) -7

**B 71**

- a) -7                      b) -10                      c) -7                      d) -15  
e) -2                      f) -10

**B 72**

- a) -13                      b) -39                      c) -60                      d) -170  
e) -405                      f) -11 151

**B 73**

- a) -5                      b) -6                      c) 1                      d) -9  
e) -8                      f) -4                      g) -15                      h) 3

**B 74**

- a) 1                      b) 4                      c) 0                      d) -2  
e) 0                      f) 2

**B 75**

- a) 18                      b) -2                      c) -10                      d) -60  
e) 230                      f) -204

**B 76**

- a) 4                          b) -4                          c) -8                          d) -9  
e) 18                          f) -3

**B 77**

- a) 8                          b) 8                          c) 16                          d) 9  
e) 25                          f) 2

**B 78**

- a) 4                          b) 5                          c) 13                          d) -5  
e) -15                          f) -1

**B 79**

- a) 6                          b) 13                          c) 12                          d) 1  
e) 0                          f) -4                          g) -2                          h) -8  
i) 2

**B 80**

- a) 5                          b) -1                          c) 0                          d) -3  
e) 17                          f) -11

**B 81**

- a) 5                          b) 2                          c) -2                          d) -1  
e) -1                          f) -16

**B 82**

- a) 1                          b) 3                          c) 0                          d) 11

**B 83**

- a) 30                          b) -30                          c) -30                          d) 30  
e) -28                          f) 42                          g) -64                          h) -56

**B 84**

- a) -42                          b) -54                          c) 48                          d) -81  
e) -28                          f) -36                          g) 39                          h) -60

**B 85**

- a) 4                      b) -4                      c) -4                      d) -2  
e) 2                      f) 2                      g) -1                      h) -10

**B 86**

- a) 5                      b) 2                      c) -6                      d) 6  
e) -9                      f) -4                      g) 3                      h) -7

## BLÅ

**B 88**

241 stup

**B 89**

315 kroner

**B 90**

53 fyrstikker

**B 91**

57 kroner

**B 92**

44 - 37

**B 93**

3 950 kroner

**B 94**

- a) 673 frimerker/  
673 frimerke                      b) 127 frimerker/  
127 frimerke

**B 98**

- a)  $50 + 30 = 80$  (79)                      b)  $20 + 10 = 30$  (31)                      c)  $50 + 30 = 80$  (81)

**B 99**

- a)  $60 + 30 = 90$  (91)                      b)  $40 + 30 = 70$  (72)  
c)  $10 + 40 + 10 = 60$  (60)                      d)  $140 + 40 + 20 = 200$  (199)

**B 100**

- a)  $90 - 50 = 40$  (41)                      b)  $40 - 20 = 20$  (19)                      c)  $70 - 20 = 50$  (49)

**B 101**

c) 180 kroner

**B 102**

c) 120 kroner

**B 104**

- a) 36                      b) 85                      c) 161                      d) 216  
e) 348                      f) 384

**B 105**

- a) 156                      b) 555                      c) 1 134                      d) 1 311  
e) 1 560                      f) 2 632

<b>B 106</b>	a) 9 425	b) 13 272	c) 5 700
<b>B 107</b>	408 kroner	<b>B 108</b>	1 462 kroner
<b>B 109</b>	2 616 flasker	<b>B 110</b>	7 257 kroner
<b>B 111</b>	1,1 1,2 1,3 1,4 1,5 1,6 1,7 1,8 1,9 1,95		
<b>B 112</b>	10,1 10,2 10,3 10,4 10,5 10,6 10,7 10,8 10,9 10,95		
<b>B 113</b>	a) 1,31 1,32 1,33 1,34 1,35	b) se a)	
<b>B 114</b>	a) Hun må gå en vei/ Ho må gå ein veg	b) Hun kjøpte ikke is/ Ho kjøpte ikkje is	
<b>B 115</b>	28,90 kroner	<b>B 116</b>	16,50 kroner
<b>B 117</b>	a) 50 kroner	b) 75 kroner	c) 125 kroner d) 150 kroner
<b>B 118</b>	a) 10 kroner	b) 20 kroner	c) 25 kroner d) 40 kroner
<b>B 119</b>	a) 15 °C	b) -15 °C	c) 30 °C
<b>B 120</b>	a) 21 °C	b) 14 °C	c) 13 °C d) 7 °C
	e) 5 °C		
<b>B 121</b>	a) Aten 15 °C	b) Moskva -12 °C	c) 27 °C
<b>B 122</b>	a) 12 °C	b) 19 °C	
<b>B 123</b>	a) 22 °C	b) 11 °C	
<b>B 124</b>	a) 2 °C	b) 0 °C	c) -1 °C

**B 125**

a)  $-2\text{ }^{\circ}\text{C}$

b)  $2\text{ }^{\circ}\text{C}$

c)  $9\text{ }^{\circ}\text{C}$

**B 126**

a)  $-4\text{ }^{\circ}\text{C}$

b)  $-15\text{ }^{\circ}\text{C}$

c)  $5\text{ }^{\circ}\text{C}$

d)  $-36\text{ }^{\circ}\text{C}$

**B 127**

$23\text{ }^{\circ}\text{C}$

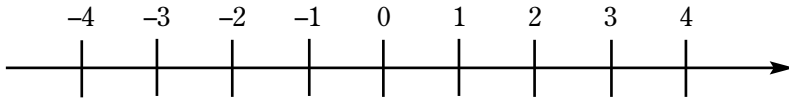
**B 128****B 129**

a)  $A = 6, B = 3, C = 0, D = -3, E = -7$

b)  $A = 1, B = -1, C = -3, D = -5, E = -7$

c)  $A = 20, B = -20, C = -60, D = -90, E = -120$

d)  $A = 100, B = -200, C = -400, D = -800, E = -1100$

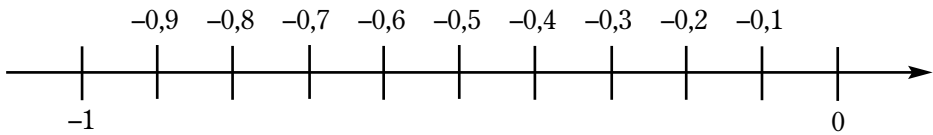
**B 130****B 131**

a)  $A = -0,1, B = -0,4, C = -0,8, D = -1,1, E = -1,4$

b)  $A = 0,5, B = -0,5, C = -3,0, D = -4,5, E = -6,0$

**B 132**

a)  $6 > 3$

b)  $4 < 8$

c)  $5 < 9$

d)  $7 > 2$

e)  $13 < 52$

f)  $0 < 1$

g)  $6 > 5$

h)  $17 < 98$

**B 133**

a)  $-3 > -5$

b)  $-6 < -2$

c)  $-15 < -1$

d)  $-2 > -20$

e)  $-17 < 0$

f)  $-8 > -13$

g)  $-2 < -1$

h)  $-1,3 > -29$

**B 134**

a)  $4 > -5$

b)  $-6 < 7$

c)  $-5 < 2$

d)  $-1 > -9$

e)  $3 > -24$

f)  $-36 < 4$

g)  $-4 < 9$

h)  $-14 < 0$



**B 135**

- a) 2                      b) 0                      c) -2                      d) -1  
e) 1                      f) -5                      g) -4                      h) -6

**B 136**

- a) 4                      b) 1                      c) 5                      d) 0  
e) 2                      f) -2                      g) -9                      h) -10

**B 137**

- a) -2                      b) 3                      c) -4                      d) 4  
e) -3                      f) -1                      g) -10                      h) -3

**B 138**

- a) -9                      b) -2                      c) -7                      d) -9  
e) -1                      f) -7                      g) -7                      h) -17

**B 141**

år -44

**B 142**

19 870 meter

**B 143**

280 °C

**B 144**

- a) -25                      b) -6                      c) -28                      d) -10  
e) -24                      f) -35                      g) -18                      h) -16

**B 145**

- a) 9                      b) 20                      c) 36                      d) 20  
e) -40                      f) -27                      g) -45                      h) 60

**B 146**

- a) 2                      b) 5                      c) 5                      d) 2

**B 147**

- a) -2                      b) -5                      c) -5                      d) -2

**B 148**

- a) -2                      b) -5                      c) -5                      d) -2

**B 149**

- a) 2                      b) 5                      c) 5                      d) 2

**B 150**

- a) 3                      b) -5                      c) 3                      d) -2  
e) -2                      f) 1                      g) -3                      h) -4

**B 151**

- a) -2                      b) -2                      c) 2                      d) -30  
e) 8                      f) -3                      g) 5                      h) -7

**B 154**

- a) 5                      b) 0                      c) -1                      d) -6

## GUL

**B 156**

- b) 30 kroner

**B 157**

- c) 350 kroner

**B 158**

- a) 0,9

**B 159**

For eksempel:

- a) 2,65                      b) 0,805                      c) 6,125                      d) 7,05  
e) 5,3405                      f) 0,6615

**B 160**

- a) 3,6                      b) 8,02                      c) 5,85                      d) 32,65  
e) 36,68                      f) 4,135

**B 161**

- a) 7,52 kg                      b) 15,72 kg                      c) 4,28 kg

**B 162**

- a) 1,70 kroner                      b) 4,00 kroner

**B 163**

44,10 kroner

**B 164**

417,96  $\approx$  418 kroner

**B 165**

59,85  $\approx$  60 kroner

**B 166**

31,72  $\approx$  31,50 kroner

**B 167**

130,70  $\approx$  130,50 kroner

<b>B 168</b>	a) 12	b) 14	c) 11	d) 19
	e) 17	f) 120	g) 65	h) 158
	i) 132	j) 17	k) 12	l) 14
<b>B 169</b>	140 kroner	<b>B 170</b>	145 kroner	
<b>B 171</b>	a) 32	b) 62	c) 32	d) 56
	e) 98	f) 205	g) 108	h) 103
<b>B 172</b>	150 kroner	<b>B 173</b>	1,30 per egg, 6,50 kroner for 5 egg	
<b>B 174</b>	a) 1,3	b) 2,6	c) 3,6	d) 6,4
	e) 4,2	f) 4,8	g) 3,8	h) 2,2
<b>B 175</b>	a) 19,20 kroner	b) 88 kroner	c) 140 kroner	
<b>B 176</b>	a) 43,75 gram	b) 44,98 kroner	c) 5,62 kroner	
<b>B 177</b>	32 uker/32 veker	<b>B 178</b>	68 skudd/68 skot	
<b>B 179</b>	a)	Epler/Eple	12,25 kroner	
		Bananer	11,16 kroner	
		Sum	23,41 kroner	
	b) 156 gram	c) 172 gram		
<b>B 180</b>	a) 20,7 gram	b) 2,1 dl	c) 3,42 kroner	
<b>B 181</b>	a) 0,54 kroner	b) 14,7 gram		
<b>B 182</b>	6 850 medlemmer			

**B 183**

- a) 20,58                      b) 644                      c) 77 562                      d) 2 271  
e) 0,2277                      f) 374,245

**B 184**

- a) 90,42 kroner    b) 9,50 kroner

**B 185**

- a) 4,25                      b) 7,22                      c) 7,88                      d) 4,22  
e) 4,06                      f) 5

**B 186**

- a) 357 kroner                      b) 143 kroner

**B 187**

- a) 59,52 kroner                      b) 40,50 kroner

**B 188**

20,93 kroner

**B 189**

8,09 kroner per kg

**B 190**

- a) 5,77 millioner kroner per km/5,77 millionar kroner per km  
b) 5 770 kroner per meter

**B 191**

1046,50 kroner

**B 192**

En kan for eksempel kjøpe boblejakke, bukse, skjorte, og strømper.  
Det blir totalt 492,90 kroner./Ein kan til dømes kjøpe boblejakke, bukse,  
skjorte, og strømper. Det blir totalt 492,90 kroner.

**B 193**

Forslag:

- 1 Hvor mange timer tok det før Titanic sank? 2 timer og 35 minutter/  
Kor mange timer tok det før Titanic sank? 2 timar og 35 minutt.
- 2 Hvor mange overlevde forliset? 711 passasjerer/  
Kor mange overlevde forliset? 711 passasjarar
- 3 Hvor mange km/t er det i én knop? 1,86 km/t = 1 knop/  
Kor mange km/t er det i éin knop? 1,86 km/t = 1 knop
- 4 Bruk svaret i c) til å finne ut hvor mange km/t 15 knop er. 27,9 km/t./  
Bruk svaret i c) til å finne ut kor mange km/t 15 knop er. 27,9 km/t

**B 194**

Forslag:

- 1 Hvor mange ganger rekker et foreldrepar å komme med mat i løpet av en time? 62,5 ganger i timen./Kor mange gonger rekker eit foreldrepar å komme med mat i løpet av ein time? 62,5 ganger i timen.
- 2 Hvor mange kjøttmeiser må overleve sin første vinter for at 4 skal bli 10 år gamle? 4 000 kjøttmeiser må overleve første vinteren./Kor mange kjøttmeisar må overleve sin første vinter for at 4 skal bli 10 år gamle? 4 000 kjøttmeisar må overleve første vinteren.
- 3 Gjør et overslag over hvor mye et kjøttmeispar veier. 12 – 40 gram/  
Gjer eit overslag over kor mykje eit kjøttmeispar veg. 12 – 40 gram.
- 4 Dersom 2000 kjøttmeiser overlever klekkingen i en skog. Hvor mange kommer til å overleve sommeren? 1000 kjøttmeiser/Dersom 2000 kjøttmeisar overlev klekkinga i ein skog, kor mange kjem til å overleve sommaren? 1000 kjøttmeisar

**B 195**

- a)  $A = 6, B = 1, C = -2, D = -6, E = -9$
- b)  $A = 150, B = -50, C = -250, D = -400, E = -500$
- c)  $A = -575, B = -675, C = -775, D = -875, E = -925$
- d)  $A = 0,1, B = -0,6, C = -1,3, D = -1,9, E = -2,5$

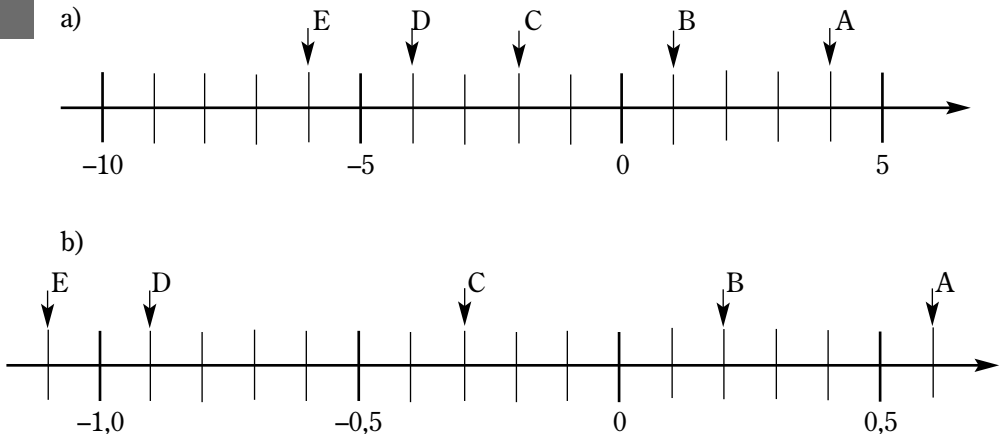
**B 196****B 197**

- a)  $2\text{ }^{\circ}\text{C}$
- b)  $-3\text{ }^{\circ}\text{C}$
- c)  $-9\text{ }^{\circ}\text{C}$

**B 198**

- a)  $-3\text{ }^{\circ}\text{C}$
- b)  $0\text{ }^{\circ}\text{C}$
- c)  $13\text{ }^{\circ}\text{C}$

**B 199**

- a)  $0,7\text{ }^{\circ}\text{C}$                       b)  $-3,1\text{ }^{\circ}\text{C}$                       c)  $5,8\text{ }^{\circ}\text{C}$                       d)  $-15,2\text{ }^{\circ}\text{C}$

**B 200**

646 år

**B 201**

år 296 f. Kr.

**B 200**

- a) Han ble født år 1368 f. Kr.                      b) 3 273 år

**B 203**

- a) Maraton blir husket i dag fordi distansen som soldaten løp, er den samme som dagens løpere må tilbakelegge når de gjennomfører et maratonløp.
- b) Denne avstanden er lengden fra Maratonsletta til Aten./Denne avstanden er lengda frå Maratonsletta til Aten.
- c) Slaget stod for 2 497 år siden (2007)./Slaget stod for 2 497 år sidan (2007).

**B 204**

- a) -56                      b) -48                      c) -49                      d) -54
- e) 56                      f) 36                      g) -72                      h) 52

**B 205**

- a) -5                      b) 9                      c) -8                      d) 9
- e) 3                      f) 23                      g) -3                      h) 8,5

**B 206**

- a) 5                      b) -13                      c) -4                      d) 0

**B 207**

- a) 7                      b) 2                      c) 0                      d) 30

**B 208**

- a)  $4 \cdot (-7) = -28$                       b)  $-6 \cdot (-2) = 12$
- c)  $-9 \cdot 7 = -63$                       d)  $\frac{-63}{-3} = 21$
- e)  $\frac{-14}{2} = -7$                       f)  $2 \cdot 2 \cdot (-3) = -12$
- g)  $\frac{10}{-2} + (-2) = -7$                       h)  $\frac{-8}{-2} - 1 = 3$

**B 209**

- a) 2                      b) -4                      c) -7

## RØD/RAUD

**B 210** a) 224 kr b) 26 kr

**B 211** Hver av de 5 delene blir 152 cm lange./Kvar av dei 5 delane blir 152 cm lange.

**B 212** 7,50 kroner **B 213** 4 600 meter

**B 214** 218 kroner **B 215** 272 kroner

**B 216** a) Dagsaviser kommer ut 7 dagar i uken. På 4 uker blir det 336 kroner./  
Dagsaviser kjem ut 7 dagar i veka. På 4 veker blir det 336 kroner.  
b) 708 kroner

**B 217** 5 085 kroner

**B 218** a) De trenger 800 fliser/ Dei treng 800 fliser  
b) 404,25 kroner c) 2608,20 kroner d) 356 kroner e) 4275,85 kroner

**B 219** 8. klasse skal arrangere et sykkelløp, og skal blande saft til deltakerne. De skal blande 220 l saft med 6,5 dl saftkonsentrat. Det er plass til 1 dl saft i hvert glass./8. klasse skal arrangere eit sykkelløp, og skal blande saft til deltakarane. Dei skal blande 220 l saft med 6,5 dl saftkonsentrat. Det er plass til 1 dl saft i kvart glass.

- a) Hvor mange glass saft har de totalt?/Kor mange glas saft har dei totalt?  
b) Det er 100 deltakere på løpet. Hvor mye saft får de hver?/Det er 100 deltakerar på løpet. Kor mykje saft får dei kvar?  
c) Hva er blandingsforholdet mellom saft og konsentrat i dette tilfellet? Synes du dette er et passe blandingsforhold?/Kva er blandingsforholdet mellom saft og konsentrat i dette tilfellet? Synes du dette er eit passe blandingsforhold?

**B 220** a) 28 vasker/28 vaskar b) 1,37 kroner per vask  
c) 0,086 kroner per plagg

**B 221** a) 25,47 kroner b) 13,02 kroner

**B 222**

6,72 kroner

**B 223**105,7 m<sup>3</sup>**B 224**

- a) 7 650 000 kg      b) 7 650 tonn      c) 1 177 lastebiler/  
lastebilar
- d) 127,5 kg per jeger      e) 1,7 kg per innbygger/innbyggjar

**B 225**

- a) 375,72 kroner      b) 17,35 kr pr. kg      c) 51 (50,1) beger
- d) 10,41 kroner per kg

**B 226**

- a) 65 øre      b) 315 250 kroner      c) 3,65 kroner per skinn

**B 227**

- a) 959 000 kroner      b) 831 500 kroner
- c) 6 995 kr per m<sup>2</sup> for A, og 7 749 kr per m<sup>2</sup> for B
- d) Bolig A var billigere enn bolig B per m<sup>2</sup>, fordi bolig A er større enn bolig B./  
Bolig A var billigere enn bustad B per m<sup>2</sup>, fordi bustad A er større enn bustad B.

**B 228**

2 050 dm

**B 229**

- a) 4,54 kroner      b) 1,76 kroner

**B 230**

- a) Hvor stor var hver av vannkannene de benyttet i båten? 20 l/  
Kor stor var kvar av vannkannene dei brukte i båten? 20 l
- b) Benytt hastigheten flåten hadde den dagen den hadde en distanserekord  
til å finne ut hvor langt de ville nå på en uke med den hastigheten. 910 km  
eller 497 sjømil./Bruk farten flåten hadde den dagen den hadde ein  
distanserekord til å finne ut kor langt dei ville nå på ei veke med den  
farten. 910 km eller 497 sjømil.
- c) De har brukt 140 liter vann den første uka. Hvor mye vann har de igjen?/  
Dei har brukt 140 liter vatn den første uka. Kor mykje vatn har dei att?
- d) Neste dag brukte de 25 liter vann. Hvor mye har de benyttet totalt så langt?/  
Neste dag brukte dei 25 liter vatn. Kor mykje har dei brukt totalt så langt?



**B 231**

- a) Hvor mye veier normalt en blåhvalunge etter 2 døgn? 2 200 kg./  
Kor mykje veg normalt ein blåkvalunge etter 2 døgn? 2 200 kg.
- b) Hvor mye veier den etter en måned(30 dager)? 5 tonn/Kor mykje veg han  
etter ein måned(30 dagar)? 5 tonn
- c) Hvor mye har hvalungen gått opp i vekt siden den ble født?/Kor mykje har  
kvalungen gått opp i vekt sidan han blei fødd?
- d) Hvor mange ganger tyngre er en stor voksen blåhval enn en 7 måneder  
gammel blåhvalunge?/Kor mange gonger tyngre er ein stor vaksen  
blåkval enn ein 7 månader gammal blåkvalunge?

**B 232**

- a) 4,2                      b) 30,1                      c) 6 297,6                      d) 25 080
- e) 2 407,4                      f) 1 014

**B 233**

- a) 1 090                      b) 1 490                      c) 4                      d) 60
- e) 29                      f) 2 942

**B 234**

- a) 5 654                      b) 31                      c) 682                      d) 49
- e) 38                      f) 616

**B 235**

730,50 kroner

**B 236**

- a) 32,39 kroner                      b) 6,33 kg

**B 237**

Det kan være vanskelig å se direkte om dette tallet blir for stort eller for lite. Det ene tallet reduseres med 2, mens det andre tallet økes med 4. Det er grunn til å tro at siden hun øker det ene tallet mer enn hun reduserer det andre, vil utregningen hennes vise et tall som er litt for stort. Dette er ikke en regel./Det kan vere vanskeleg å sjå direkte om dette talet blir for stort eller for lite. Det eine talet minkar med 2, medan det andre tallet aukar med 4. Det kan vere grunn til å tru at sidan ho aukar det eine talet meir enn ho minkar det andre, vil utrekinga hennar vise eit tal som er litt for stort. Dette er ikkje ein regel.

**B 238**

41,35 kr per kg

**B 239**

Se B237. Det er grunn til å tro at siden han øker det ene tallet mer enn han reduserer det andre vil utregningen vise et tall som er litt for stort./  
Sjå B237. Det er grunn til å tru at sidan han aukar det eine talet meir enn han minkar det andre vil utrekninga vise eit tal som er litt for stort.

**B 240**

Varene koster i underkant av 140 kroner; 135,98 kroner./  
Varane kostar i underkant av 140 kroner; 135,98 kroner.

**B 241**

a) 62                      b) 242                      c) 380                      d) 140

**B 242**

270,71 kroner

**B 243**

a) 77 760                      b) 28 382 400

**B 244**

a) 7,13 fotballbaner/  
7,13 fotballbanar                      b) 30 039 meter                      c) 6 066,7 tonn

**B 245**

a) 5 767 liter                      b) 19 223 glass/  
19 223 glas                      c) 53 mennesker/  
53 menneske

**B 246**

a) 27 280 tonn                      b) 33,55 millioner/  
33,55 millionar                      c) 478 sviller per dag

**B 247**

a) 550 meter                      b) 3 019 meter

**B 248**

a) Aristoteles ble født i år 384 f.Kr., og døde 322 f.Kr./  
Aristoteles vart fødd i år 384 f.Kr., og døydd 322 f.Kr.

b) Platon ble født i år 427 f.kr., og døde 347 f.kr./  
Platon vart fødd i år 427 f.kr., og døydd 347 f.kr.

**B 249**

a) Cæsar ble født i år 100 f.Kr., og ble 56 år gammel./  
Cæsar vart fødd i år 100 f.Kr., og blei 56 år gamal.

b) Kleopatra ble født i år 69 f.Kr., og døde 66 år gammel./  
Kleopatra vart fødd i år 69 f.Kr., og døydd 66 år gammal.

**B 250**

- a) -104      b) 136      c) 3,92      d) -1,862  
 e) -85,05      f) 1,4848

**B 251**

- a) 9      b) -8,5      c) -8,6      d) -8,6  
 e) -62,25      f) 8,56      g) -6,5      h) 0,6372

**B 252**

- a) -7      b) 2      c) -11,7      d) -0,2

**B 253**

- a) 1      b) -10,5      c) -2,2      d) 2,2  
 e) -29,2      f) 29,1

**B 254**

- a) -2      b) -35,28      c) -41,83

**B 255**

- a) 2,7      b) 13      c) 1

**B 256**

a)

-	-2	3	7	-4	9	
2	4	-1	-5	6	-7	
-3	-1	-6	-10	1	-12	
-7	-5	-10	-14	-3	-16	
12	14	9	5	16	3	
-15	-13	-18	-22	-11	-24	
Sum	-3	-23	-39	5	-47	-107
Samlet sum/Samla sum						

b)

4	-1	-5	6	-7	
-1	-6	-10	1	-12	
-5	-10	-14	-3	-16	
14	9	5	16	3	
-13	-18	-22	-11	-24	
-1	-26	-46	9	-56	-120
Samlet sum/Samla sum					

**B 257**

8	-2	-3	7	0	-2
-7	-13	②	⑥	①	⑤
⑤	③	①	⑤	④	-1

a)

	Antall kamper/ Talet på kampar	Vunnet kamp/ Vunne kampar	Uavgjort kamp Uavgjorde kampar	Tapt kamp	Målforskjell/ Mål- skilnad	Poeng	Plassering
Larvik	4	1	3	0	4	5	3
Sjetne	4	0	2	2	-5	2	5
Lunner	4	4	0	0	5	8	1
Gjerpen	4	0	2	2	-3	2	4
Fåberg	4	2	1	1	8	5	2
Tertnes	4	1	0	3	-9	2	6

b) Larvik har 3 uavgjorte kamper. En av dem *må* ha vært mot Sjetne. Dermed ble resultatet 17-17. /Larvik har 3 uavgjorde kamper. Ein *må* ha vore mot Sjetne. Da må resultatet vere 17-17.

c) Slutt Tabellen:

	Antall kamper/ Talet på kampar	Vunnet kamp/ Vunne kampar	Uavgjort kamp Uavgjorde kampar	Tapt kamp	Målforskjell/ Mål- skilnad	Poeng	Plassering
Larvik	5	1	3	1	3	5	3
Sjetne	5	1	2	2	1	4	4
Lunner	5	5	0	0	6	10	1
Gjerpen	5	0	2	3	-6	3	6
Fåberg	5	2	1	2	2	6	2
Tertnes	5	2	0	3	-6	4	5

a) Hvor gammel ble Nebukadnesar? 68 år/  
Kvor gammel vart Nebukadnesar? 68 år0

b) Hvor gammel var han da hæren hans slo egypterne? 44 år/  
Kor gammel var han da hæren hans slo egyptarane? 44 år

## PRØV DEG SELV/PRØV DEG SJØLV

**PB 1**

- a) 447                      b) 3 385                      c) 111                      d) 835

**PB 2**

- a) 18,17                      b) 6,24                      c) 1,37                      d) 18,918

**PB 3**

- a) 39                      b) 1,1

**PB 4**

- a) 5,63                      b) 1,86

**PB 5**

- |   |   |
|---|---|
| a) Partall/Partal                               | b) oddetall/oddetal                             |
| c) printall og oddetall/<br>printal og oddetal  | d) printall og oddetall/<br>printal og oddetal  |
| e) partall/partal                               | f) printall og oddetall/<br>printall og oddetal |
| g) printall og oddetall/<br>printall og oddetal | h) oddetall/oddetal                             |

**PB 6**

- a) 12,53 kroner                      b) 12,50 kroner

**PB 7**

65 kroner

**PB 8**

19 lass

**PB 9**

- a)                       $A \approx -8$                        $B = -5$                        $C = -1$                        $D = 2$

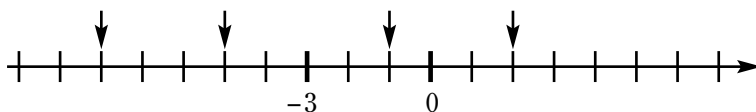

- b)  $A = -375$ ,  $B = -300$ ,  $C = -150$ ,  $D = -25$ ,  $E = 50$ ,  $F = 175$

**PB 10**

146,6 °C

**PB 11**

- a) 1172 år                      b) 2672 år

**PB 12**

- |       |        |        |         |
|-------|--------|--------|---------|
| a) 56 | b) -72 | c) -42 | d) 132  |
| e) -6 | f) -21 | g) 8   | h) -6,5 |

## FYLKESOPPGAVE ROGALAND/ FYLKESOPPGÅVE ROGALAND

FB 1

a) Stavanger

b) Bryne 8 618

Jørpeland 5 631

Kopervik 6 592

Sauda 4 258

Skudeneshavn 3 214

Åkrehamn 9 452

Sum 37 765

(Befolkning og areal i tettsteder  
per 1.1.2006, Statistisk sentralbyrå)

c) 23348

FB 2

a) 70 000 kg

b) 1 077 personer/1 077 personar

FB 3

175 820 sardineskelokk

FB 4

a)  $\approx 28,3$  g

b) USA, Storbritannia

c)  $\approx 99$  g

FB 5

597 m

FB 6

a) Billetter med redusert pris. Gis. bl.a. til pensjonister./Billetter med redusert pris. M.a. pensjonistar får dei.

b) Eksempel/Døme: A: 890 kr

FB 7

a) År 872

b) Harald Hårfagre skal i Hafrsfjord ha beseiret de siste motstanderne av sitt nye kongedømme i Norge. Slaget ble utkjempet mot de to småkongene Kjøtve og Haklang som trolig regjerte på Sør- og Sørvestlandet./Harald Hårfagre skal i Hafrsfjord ha sgra over dei siste motstandarane av det nye kongedømmet hans i Norge. Han slost mot dei to småkongane Kjøtve og Haklang som truleg regjerte på Sør- og Sørvestlandet.

# FASIT TIL KAPITTEL C

C 2

- a)  $\frac{1}{4}$                       b)  $\frac{2}{3}$                       c)  $\frac{6}{8}$                       d)  $\frac{14}{34}$   
e)  $\frac{1}{5}$                       f)  $\frac{1}{2}$                       g)  $\frac{1}{2}$                       h)  $\frac{9}{7}$

C 3



C 4

- a) 
- b)  $\frac{1}{3} > \frac{1}{6}$

C 5

- a)  $\frac{1}{5} < \frac{1}{3}$                       b)  $\frac{1}{7} > \frac{1}{9}$                       c)  $\frac{1}{8} < \frac{1}{2}$                       d)  $\frac{7}{12} > \frac{7}{15}$   
e)  $\frac{6}{17} > \frac{6}{34}$                       f)  $\frac{120}{7} > \frac{120}{14}$

C 6

- a)  $\frac{1}{3} < \frac{2}{3}$

b)

Brøk	Teller/Teljar	Nevner/Nemnar
$\frac{1}{3}$	1	3
$\frac{2}{3}$	2	3

Nevnerne er like/Nemnarane er like

C 7

- a)  $\frac{1}{6} < \frac{5}{6}$                       b)  $\frac{6}{17} > \frac{3}{17}$                       c)  $\frac{1}{2} < \frac{3}{2}$                       d)  $\frac{5}{9} > \frac{2}{9}$   
e)  $\frac{6}{13} > \frac{2}{17}$                       f)  $\frac{1}{17} < \frac{4}{17}$                       g)  $\frac{2}{3} > \frac{1}{3}$                       h)  $\frac{1}{5} < \frac{3}{4}$

- i)  $\frac{1}{10} < \frac{1}{3}$       j)  $\frac{5}{5} = 1$       k)  $\frac{6}{6} = \frac{22}{22}$       l)  $\frac{13}{12} > \frac{2}{2}$   
m)  $\frac{17}{1} = 17$       n)  $\frac{1}{18} < \frac{1}{15}$       o)  $\frac{15}{3} < 15$       p)  $\frac{223}{11} > \frac{222}{11}$   
q)  $\frac{2}{3} < 1$       r)  $\frac{10}{10} = \frac{1}{1}$

**C 8**

- a)  $\frac{1}{6}$       b)  $\frac{3}{6}$       c)  $\frac{3}{6}$       d)  $\frac{3}{6}$   
e) b, c og d      f) De er like store/Dei er like store

**C 9**

- a)  $\frac{10}{15}$       b)  $\frac{15}{35}$       c)  $\frac{20}{45}$       d)  $\frac{25}{30}$   
e)  $\frac{40}{50}$

**C 10**

- a)  $\frac{21}{28}$       b)  $\frac{28}{35}$       c)  $\frac{14}{49}$       d)  $\frac{21}{56}$   
e)  $\frac{42}{56}$

**C 11**

- a)  $\frac{10}{15}$       b)  $\frac{24}{42}$       c)  $\frac{18}{30}$       d)  $\frac{35}{75}$

**C 12**

- a)  $\frac{4}{18}$       b)  $\frac{6}{18}$       c)  $\frac{15}{18}$       d)  $\frac{9}{18}$

**C 13**

- a)  $\frac{24}{32}$       b)  $\frac{20}{32}$       c)  $\frac{16}{32}$       d)  $\frac{6}{32}$

**C 14**

- a)  $\frac{21}{42}$       b)  $\frac{18}{42}$       c)  $\frac{28}{42}$       d)  $\frac{35}{42}$

**C 15**

- a)  $\frac{5}{9}$       b) Tone får 800 kr, og Arild får 1000 kr.

**C 16**

Pelle må bære ut 90 kasser og Salman må bære ut 80 kasser.  
Da står det 70 kasser igjen til Nina./Pelle må bære ut 90 kassar og Snorre må bære ut 80 kasser. Da står det 70 kassar att til Nina.

**C 17**

Det var flest som fikk karakteren 4./Det var flest som fekk karakteren 4.



**C 18**

- a)  $\frac{5}{7} > \frac{3}{14}$       b)  $\frac{3}{5} > \frac{1}{2}$       c)  $\frac{6}{11} > \frac{5}{22}$       d)  $\frac{3}{13} > \frac{2}{26}$
- e)  $\frac{1}{3} < \frac{2}{5}$       f)  $\frac{3}{5} < \frac{5}{6}$

**C 19**

- a) Dele på 2 både i teller og nevner.      b) Dele på 2 både i teller og nevner.  
c) Dele på 4 både i teller og nevner.

**C 20**

- a)  $\frac{2}{4}$       b)  $\frac{3}{4}$       c)  $\frac{10}{20}$       d)  $\frac{9}{15}$
- e)  $\frac{1}{2}$       f)  $\frac{4}{18}$       g)  $\frac{8}{24}$       h)  $\frac{11}{30}$

**C 21**

- a)  $\frac{6}{10} = \frac{3}{5}$       b)  $\frac{27}{36} = \frac{3}{4}$       c)  $\frac{18}{45} = \frac{2}{5}$       d)  $\frac{15}{50} = \frac{3}{10}$
- e)  $\frac{17}{34} = \frac{1}{2}$       f)  $\frac{32}{72} = \frac{4}{9}$

**C 22**

- a)  $\frac{3}{4}$       b)  $\frac{1}{2}$       c)  $\frac{1}{6}$       d)  $\frac{1}{3}$
- e)  $\frac{3}{5}$       f)  $\frac{3}{5}$       g)  $\frac{3}{4}$       h)  $\frac{1}{4}$

**C 24**

- a)  $1 \frac{1}{3}$       b)  $1 \frac{2}{5}$       c)  $2 \frac{1}{5}$       d)  $2 \frac{2}{3}$
- e)  $2 \frac{2}{9}$       f)  $3 \frac{1}{7}$       g)  $3 \frac{11}{13}$       h)  $9 \frac{2}{7}$

**C 25**

Ekspeditøren har rett.       $\frac{7}{4} = 1 \frac{3}{4}$

**C 26**

- a)  $\frac{5}{4}$       b)  $\frac{11}{4}$       c)  $\frac{7}{2}$       d)  $\frac{23}{4}$
- e)  $\frac{25}{3}$       f)  $\frac{39}{5}$       g)  $\frac{55}{3}$       h)  $\frac{63}{5}$

**C 27**

- a) 1,5      b) 2,25      c) 3,75      d) 6,4
- e) 12,6      f) 2,21      g) 4,75      h) 4,37
- i) 2,33      j) 2,06

**C 28**

$\frac{1}{3}$

**C 29**

a)  $\frac{7}{10}$

b)  $\frac{3}{10}$

**C 30**

a)  $\frac{1}{4}$

b)  $\frac{3}{4}$

**C 31**

a)  $\frac{3}{10}$

b)  $\frac{1}{4}$

c)  $\frac{1}{3}$

d)  $\frac{11}{64}$

**C 32**

Brøkform	Desimalform
$\frac{1}{4}$	$1 : 4 = 0,25$
$\frac{3}{4}$	$3 : 4 = 0,75$
$\frac{5}{4}$	$5 : 4 = 1,25$
$\frac{6}{4}$	$6 : 4 = 1,5$
$\frac{3}{2}$	$3 : 2 = 1,5$

**C 33**

a) 0,80

b) 0,43

c) 0,67

d) 1,60

e) 3,25

f) 0,25

g) 0,68

h) 0,13

i) 0,17

j) 3,40

**C 34**

a) 0,9

b) 0,7

c) 0,37

d) 6,1

e) 0,21

f) 1,53

g) 0,19

h) 3,471

i) 0,04

j) 0,13

k) 0,017

l) 0,025

**C 35**

a)

Brøkform	Desimalform
$\frac{3}{10}$	$3 : 10 = 0,3$
$\frac{42}{10}$	$42 : 10 = 4,2$
$\frac{361}{100}$	$361 : 100 = 3,61$
$\frac{2}{100}$	$2 : 100 = 0,02$

b)  $\frac{2}{100}$ ,  $\frac{3}{10}$ ,  $\frac{361}{100}$ , og  $\frac{42}{10}$ **C 36**a)  $0,57 < 0,63$ b)  $0,38 < 0,47$ c)  $0,55 > 0,53$ d)  $1,6 < 1,75$ e)  $4,5 > 4,2$ f)  $0,44 < 0,55$ **C 37**a)  $\frac{2}{7} < 1$ b)  $\frac{3}{4} > 0,6$ c)  $\frac{2}{3} < 0,8$ d)  $\frac{1}{4} = 0,25$ e)  $\frac{8}{16} < 0,55$ f)  $0,7 > \frac{3}{5}$ g)  $\frac{5}{9} < \frac{8}{11}$ h)  $0,67 > \frac{2}{3}$ **C 38**

2,5 dl, 3,5 dl og 5 dl

**C 39**a)  $\frac{3}{10}$ b)  $\frac{7}{100}$ c)  $\frac{21}{100}$ d)  $\frac{8}{10}$ e)  $\frac{24}{100}$ f)  $\frac{32}{100}$ g)  $\frac{1}{100}$ h)  $\frac{93}{100}$ **C 40**

Brøk	Desimalform	Brøk med 100 som nevner/nemnar
$\frac{3}{20}$	$3 : 20 = 0,15$	$\frac{15}{100}$
$\frac{4}{25}$	$4 : 25 = 0,16$	$\frac{16}{100}$

**C 41** a) 91 %                      b) 9 %

**C 42** a) 88 %                      b) 12 %

**C 43** a) 29 elever/29 elever                                      b) 71 elever/71 elever

**C 44** a) 10 elever/10 elever                                      b) 40 elever/40 elever

**C 45** 249 elever/249 elever

**C 46** a) 1 kr                      b) 2 kr                      c) 2 kr                      d) 4 kr  
e) 30 kr

**C 48** a) 10 kr                      b) 180 kg                      c) 175 kg                      d) 60 kr  
e) 840 kr                      f) 2 kr                      g) 102,6 l                      h) 6,72 kr

**C 49** a) 80 elever/  
80 elever                      b) 672 elever/  
672 elever                      c) 256 elever/  
256 elever

**C 50** a) 840 kr                      b) 280 kr                      c) 9 180 kr                      d) 267 kr  
e) 1 360 kr                      f) 9,80 kr

**C 51** a) 5 600 kr                      b) 6 000 kr

**C 52** a) Sporten AS                      1 614 kr  
Sporteksperten AS 1 846 kr                      b) Det er billigst på Sporten AS/  
Det er billigast på Sporten AS

## BLÅ

**C 54** a)  $\frac{4}{7}$                       b)  $\frac{8}{5}$

**C 55** a)  $\frac{1}{6}$                       b)  $\frac{3}{5}$                       c)  $\frac{10}{7}$

**C 56**

a)  $\frac{1}{4}$

b)  $\frac{3}{4}$

**C 57**

a)  $\frac{4}{7}$

b)  $\frac{3}{7}$

**C 58**

a)  $\frac{1}{2}$

b)  $\frac{1}{4}$

c)  $\frac{1}{3}$

d)  $\frac{3}{8}$

e)  $\frac{5}{8}$

f)  $\frac{3}{6}$

**C 61**

a)  $\frac{1}{10}$

b)  $\frac{4}{10}$

c)  $\frac{2}{10}$

d)  $\frac{3}{10}$

e)  $\frac{7}{10}$

**C 63**

a) 12 ruter

b) 8 ruter

c)  $\frac{2}{24}$

**C 65**

A =  $\frac{1}{4}$ , B =  $\frac{3}{4}$ , C =  $\frac{5}{4}$ , D =  $\frac{7}{4}$  og E =  $\frac{9}{4}$

**C 66**

A =  $\frac{1}{6}$ , B =  $\frac{5}{6}$ , C =  $\frac{6}{6}$ , D =  $\frac{10}{6}$  og E =  $\frac{12}{6}$

**C 67**

A =  $\frac{2}{5}$ , B =  $\frac{4}{5}$ , C =  $\frac{6}{5}$ , D =  $\frac{8}{5}$  og E =  $\frac{9}{5}$

**C 68**

A =  $\frac{2}{10}$ , B =  $\frac{8}{10}$ , C =  $\frac{14}{10}$ , D =  $\frac{20}{10}$  og E =  $\frac{22}{10}$

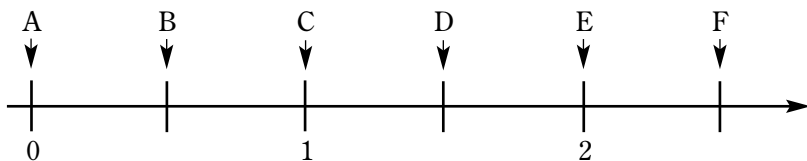
**C 69****C 70**

c, d, f og h

**C 71**

a)  $\frac{1}{6} > \frac{1}{9}$

b)  $\frac{1}{12} < \frac{1}{10}$

c)  $\frac{1}{2} > \frac{1}{5}$

d)  $\frac{7}{13} < \frac{7}{9}$

e)  $\frac{5}{3} > \frac{5}{5}$

f)  $\frac{58}{37} < \frac{58}{5}$

**C 72**Nei,  $\frac{1}{3}$  er større enn  $\frac{1}{4}$ .**C 73**

- a)  $\frac{5}{7} > \frac{1}{7}$       b)  $\frac{15}{13} < \frac{18}{13}$       c)  $\frac{1}{3} < \frac{2}{3}$       d)  $\frac{5}{11} > \frac{3}{11}$
- e)  $\frac{6}{15} < \frac{7}{15}$       f)  $\frac{2}{7} > \frac{1}{7}$

**C 74**

- a)  $\frac{1}{2}$       b)  $\frac{3}{4}$       c)  $\frac{1}{4}$       d)  $\frac{5}{8}$

**C 75**

- a)  $\frac{1}{3}, \frac{2}{6}, \frac{3}{9}$  og  $\frac{4}{12}$       b)  $\frac{9}{12} = \frac{6}{8} = \frac{3}{4}$
- c)  $\frac{1}{3} > \frac{3}{10}$       d)  $\frac{1}{2} < \frac{7}{12}$

**C 76**

- a)  $\frac{1 \cdot 4}{4 \cdot 4} = \frac{4}{16}$       b)  $\frac{1 \cdot 4}{3 \cdot 4} = \frac{4}{12}$
- c)  $\frac{1 \cdot 4}{2 \cdot 4} = \frac{4}{8}$       d)  $\frac{1 \cdot 4}{2 \cdot 4} = \frac{4}{8}$

**C 77**

- a)  $\frac{3}{6}$       b)  $\frac{9}{12}$       c)  $\frac{12}{15}$       d)  $\frac{15}{21}$
- e)  $\frac{24}{27}$

**C 78**

- a)  $\frac{12}{16}$       b)  $\frac{20}{28}$       c)  $\frac{32}{40}$       d)  $\frac{40}{60}$
- e)  $\frac{48}{48}$

**C 79**

- a)  $\frac{2}{3} = \frac{6}{9}$       b)  $\frac{3}{7} = \frac{9}{21}$       c)  $\frac{3}{4} = \frac{9}{12}$       d)  $\frac{4}{7} = \frac{16}{28}$
- e)  $\frac{2}{5} = \frac{10}{25}$       f)  $\frac{3}{5} = \frac{15}{25}$       g)  $\frac{7}{11} = \frac{21}{33}$       h)  $\frac{4}{9} = \frac{16}{36}$

**C 80**

- a)  $\frac{18}{24}$       b)  $\frac{16}{24}$       c)  $\frac{4}{24}$       d)  $\frac{14}{24}$
- e)  $\frac{2}{24}$

**C 81**

a)  $\frac{3}{5} > \frac{8}{15}$

b)  $\frac{2}{3} = \frac{6}{9}$

c)  $\frac{3}{4} < \frac{10}{12}$

d)  $\frac{9}{20} > \frac{2}{5}$

e)  $\frac{7}{18} > \frac{1}{3}$

f)  $\frac{12}{16} = \frac{3}{4}$

g)  $\frac{1}{6} = \frac{5}{30}$

h)  $\frac{9}{8} > \frac{25}{24}$

i)  $\frac{16}{4} < 5$

**C 82**

Brøkform	Desimalform
$\frac{1}{2}$	1 : 2 = 0,5
$\frac{3}{5}$	3 : 5 = 0,6
$\frac{3}{4}$	3 : 4 = 0,75
$\frac{4}{5}$	4 : 5 = 0,8
$\frac{3}{6}$	3 : 6 = 0,5
$\frac{6}{4}$	6 : 4 = 1,5

**C 83**

a) 0,7

b) 0,3

c) 1,3

d) 2,5

e) 0,07

f) 0,03

g) 0,035

h) 0,007

**C 84**

a) 0,9

b) 0,15

c) 3,2

d) 5,05

e) 2,672

f) 0,872

g) 0,045

h) 0,009

**C 85**

5 845 kr

**C 86**

2,50 kr

**C 87**

3,50 kr

**C 88**

a)  $\frac{6}{7} < 1$

b)  $\frac{4}{5} = 0,8$

c)  $\frac{2}{5} < 0,5$

d)  $0,6 > \frac{6}{12}$

e)  $0,25 = \frac{1}{4}$

f)  $\frac{3}{4} > \frac{14}{20}$

g)  $1,5 = \frac{3}{2}$

h)  $\frac{7}{3} > 2$

i)  $\frac{1}{3} < 0,4$

**C 89**

a)  $\frac{4}{10}$

b)  $\frac{42}{10}$

c)  $\frac{9}{10}$

d)  $\frac{69}{10}$

e)  $\frac{85}{100}$

f)  $\frac{8}{100}$

g)  $\frac{235}{100}$

h)  $\frac{26}{100}$

**C 90**

a)  $\frac{2}{3}$ , forkorta med 2

b)  $\frac{1}{2}$ , forkorta med 4

**C 91**

$$\frac{6:6}{12:6} = \frac{1}{2}$$

**C 92**

a)  $\frac{2}{3}$

b)  $\frac{1}{2}$

c)  $\frac{5}{6}$

d)  $\frac{9}{10}$

e)  $\frac{3}{4}$

f)  $\frac{7}{8}$

g)  $\frac{11}{12}$

h)  $\frac{14}{15}$

**C 93**

a)  $\frac{4}{10}$

b)  $\frac{8}{20}$

c)  $\frac{10}{25}$

d)  $\frac{2}{5}$

**C 94**

a)  $\frac{8}{10} = \frac{4}{5}$

b)  $\frac{9}{12} = \frac{3}{4}$

c)  $\frac{15}{25} = \frac{3}{5}$

d)  $\frac{6}{36} = \frac{1}{6}$

e)  $\frac{14}{21} = \frac{2}{3}$

f)  $\frac{8}{12} = \frac{2}{3}$

**C 95**

a)  $\frac{1}{2}$

b)  $\frac{1}{3}$

c)  $\frac{1}{3}$

d)  $\frac{3}{4}$

**C 96**

a)  $\frac{20}{40}$

b)  $\frac{2}{6}$

c)  $\frac{25}{21}$

**C 97**

a)  $\frac{4}{3}, \frac{5}{4}, \frac{6}{5}$  og  $\frac{7}{6}$

b)  $1\frac{1}{3}, 1\frac{1}{4}, 1\frac{1}{5}$  og  $1\frac{1}{6}$



**C 98**

a)  $2 \frac{1}{2}$

b)  $2 \frac{1}{5}$

c)  $2 \frac{2}{3}$

d)  $2 \frac{1}{3}$

e)  $2 \frac{1}{4}$

f)  $3 \frac{1}{5}$

g) 3

h)  $3 \frac{1}{4}$

i)  $3 \frac{3}{7}$

j)  $9 \frac{1}{3}$

k)  $5 \frac{2}{3}$

l)  $5 \frac{3}{4}$

**C 99**

a)  $\frac{7}{4}$

b)  $\frac{6}{4}$

c)  $\frac{11}{6}$

d)  $\frac{8}{5}$

e)  $\frac{13}{7}$

f)  $\frac{9}{7}$

g)  $\frac{11}{5}$

h)  $\frac{11}{4}$

i)  $\frac{20}{3}$

j)  $\frac{27}{5}$

k)  $\frac{27}{4}$

l)  $\frac{32}{9}$

**C 100**

a) 1)  $\frac{27}{30}$

2)  $\frac{3}{30}$

b) 1)  $\frac{55}{65}$

2)  $\frac{10}{65}$

**C 101**

Brøkform	Desimalform	Prosentform
$\frac{7}{100}$	0,07	7 %
$\frac{18}{100}$	0,18	18 %
$\frac{50}{100}$	0,50	50 %
$\frac{85}{100}$	0,85	85 %
$\frac{1}{4}$	0,25	25 %
$\frac{1}{5}$	0,20	20 %
$\frac{60}{100}$	0,60	60 %
$\frac{150}{100}$	1,50	150 %

**C 102**

a) 26 %

b) 37 %

c) 62 %

<b>C 103</b>	a) 74 %, 63 % og 38 %	b) 100 % pr. oppgave		
<b>C 104</b>	a) 25 %	b) 50 %	c) 75 %	d) 100 %
	e) 20 %	f) 60 %	g) 25 %	h) 40 %
<b>C 105</b>	60 %	<b>C 106</b>	45 %	
<b>C 107</b>	65 %			
<b>C 108</b>	a) 95 %	b) 84 %	c) 100 %	d) 75 %
<b>C 109</b>	a) 5 kr	b) 8 tilskuere/ 8 tilskodarar	c) 1 kg	
<b>C 110</b>	a) 10 kr	b) 16 tilskuere/ 16 tilskodarar	c) 2 kg	
<b>C 111</b>	a) 5 kr	b) 20 kr	c) 30 kr	
<b>C 112</b>	a) 10 kr	b) 50 kr	c) 90 kr	
<b>C 113</b>	a) 10 elever/ 10 elevar	b) 20 %	c) 80 %	
<b>C 114</b>	a) 20 elever/ 20 elevar	b) 80 %	c) 20 %	
<b>C 115</b>	a) $\frac{5}{100}$	b) $\frac{18}{100}$	c) $\frac{12}{100}$	d) $\frac{1}{100}$
	e) $\frac{45}{100}$	f) $\frac{92}{100}$	g) $\frac{115}{100}$	h) $\frac{33}{100}$
<b>C 116</b>	a) 0,03	b) 0,06	c) 0,55	d) 0,98
	e) 1,05	f) 0,01	g) 3,15	h) 2,1

<b>C 117</b>	a) 39 elever/ 39 elever	b) 10 kr	c) 18 epler/ 18 eple	d) 34 kg
	e) 24 trær/24 tre	f) 40,50 kr		
<b>C 119</b>	a) 52	b) 208		
<b>C 119</b>	a) 175	b) 75		
<b>C 120</b>	a) 18	b) 42		
<b>C 121</b>	1 680 kr	<b>C 122</b>	15 kr	
<b>C 123</b>	376 kr	<b>C 124</b>	60 klinkekuler	
<b>C 125</b>	429 kr	<b>C 126</b>	2 592 kr	
<b>C 127</b>	1 265 kr	<b>C 128</b>	864 bøker	
<b>C 129</b>	1 914 tv-er/1 914 tv-ar	<b>C 130</b>	736 biler/736 bilar	
<b>C 131</b>	780 kr	<b>C 132</b>	90 trær/90 tre	
<b>C 133</b>	224 400 kr			
<b>C 134</b>	a) 9 kr	b) 81 kr		
<b>C 135</b>	391 kr			
<b>C 136</b>	a) 60 kr	b) 1 008 kr	c) 268 kr	

## GUL

C 137

Se side 183/Sjå side 183

C 138

a)  $\frac{1}{6}$

b)  $\frac{1}{2}$

c)  $\frac{3}{2}$

d)  $\frac{8}{3}$

e)  $\frac{1}{3}$

f)  $\frac{3}{2}$

C 139

a)  $\frac{1}{8}$

b)  c)  $\frac{5}{8}$

C 140

a)  $\frac{1}{3}$

b) 550 kr

C 141

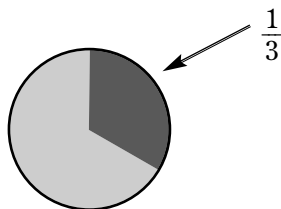

C 142

$\frac{1}{20}, \frac{1}{9}, \frac{1}{8}, \frac{1}{6}, \frac{1}{3}, \frac{1}{2}$  og  $\frac{1}{1}$

C 143

a)  $\frac{1}{6} < \frac{1}{5}$

b)  $\frac{1}{3} > \frac{1}{16}$

c)  $\frac{7}{16} > \frac{5}{16}$

d)  $\frac{1}{18} < \frac{1}{17}$

e)  $\frac{7}{3} < \frac{8}{3}$

f)  $\frac{2}{2} = \frac{3}{3}$

C 145

$a > b = c$ , fordi  $\frac{3}{7} > \frac{3}{8} = \frac{3}{8}$

C 146

Amir  $\frac{4}{16}$ , Irene  $\frac{3}{16}$ , Live  $\frac{2}{16}$ , Anders  $\frac{4}{16}$  og Bjarne  $\frac{3}{16}$

C 147

A =  $\frac{1}{4}$ , B =  $\frac{3}{4}$ , C =  $\frac{5}{4}$ , D =  $\frac{7}{4}$  og E =  $\frac{9}{4}$

C 148

A =  $\frac{1}{6}$ , B =  $\frac{5}{6}$ , C =  $\frac{6}{6}$ , D =  $\frac{10}{6}$  og E =  $\frac{12}{6}$

C 149

A =  $\frac{2}{5}$ , B =  $\frac{4}{5}$ , C =  $\frac{6}{5}$ , D =  $\frac{8}{5}$  og E =  $\frac{9}{5}$

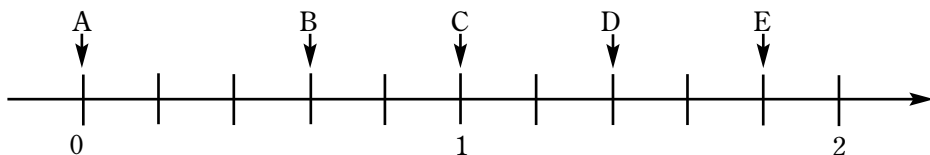
**C 150****C 151**

a)  $\frac{53}{82}$                       b)  $\frac{29}{82}$

**C 152**

a)  $\frac{185}{260}$                       b)  $\frac{62}{260}$                       c)  $\frac{13}{260}$

**C 153**

En utvider en brøk ved å gange både teller og nevner med det samme tallet./  
Ein vidar ut ein brøk ved å gange både teljar og nemnar med det same talet.

**C 154**

c) 2, 4 og 8

**C 155**

a)  $\frac{2}{3}$ ,  $\frac{4}{6}$ ,  $\frac{6}{9}$  og  $\frac{8}{12}$                       b)  $\frac{1}{2}$ ,  $\frac{2}{4}$ ,  $\frac{3}{6}$ ,  $\frac{4}{8}$ ,  $\frac{5}{10}$  og  $\frac{6}{12}$

c)  $\frac{2}{3} > \frac{5}{8}$

**C 156**

a)  $\frac{3}{6}$                       b)  $\frac{9}{12}$                       c)  $\frac{24}{27}$                       d)  $\frac{36}{51}$

e)  $\frac{54}{39}$

**C 157**

a)  $\frac{3}{4} = \frac{18}{24}$                       b)  $\frac{3}{7} = \frac{24}{56}$                       c)  $\frac{7}{23} = \frac{21}{69}$                       d)  $\frac{8}{9} = \frac{72}{81}$

e)  $\frac{21}{28} = \frac{42}{56}$                       f)  $\frac{13}{8} = \frac{91}{56}$                       g)  $\frac{7}{11} = \frac{84}{132}$                       h)  $\frac{15}{14} = \frac{120}{112}$

**C 158**

a)  $\frac{20}{40}$                       b)  $\frac{10}{40}$                       c)  $\frac{15}{40}$                       d)  $\frac{44}{40}$

e)  $\frac{104}{40}$

**C 159**

a)  $\frac{40}{70}$                       b)  $\frac{40}{65}$                       c)  $\frac{40}{100}$                       d)  $\frac{40}{92}$

e)  $\frac{40}{260}$

**C 160**

a) forkorta med 3

b) forkorta med 4

c) forkorta med 4

d) forkorta med 2

**C 161**

a)  $\frac{6}{30}$

b)  $\frac{3}{15}$

c)  $\frac{2}{10}$

d)  $\frac{1}{5}$

e)  $\frac{4}{20}$

**C 162**

a)  $\frac{15}{18} = \frac{5}{6}$

b)  $\frac{30}{35} = \frac{6}{7}$

c)  $\frac{21}{28} = \frac{3}{4}$

d)  $\frac{20}{22} = \frac{10}{11}$

e)  $\frac{56}{72} = \frac{7}{9}$

f)  $\frac{49}{42} = \frac{7}{6}$

g)  $\frac{81}{27} = \frac{9}{3}$

h)  $\frac{32}{72} = \frac{4}{9}$

**C 163**

a)  $\frac{1}{3}$

b)  $\frac{1}{3}$

c)  $\frac{9}{2}$

**C 164**

a)  $\frac{2}{6}$

b)  $\frac{28}{24}$

c)  $\frac{30}{35}$

**C 165**

a)  $\frac{4}{5} < \frac{7}{8}$

b)  $\frac{3}{4} = \frac{18}{24}$

c)  $\frac{13}{13} = \frac{47}{47}$

d)  $\frac{5}{7} > \frac{2}{3}$

e)  $\frac{5}{8} < \frac{3}{4}$

f)  $\frac{18}{1} = 18$

g)  $1 = \frac{24}{24}$

h)  $\frac{7}{8} > \frac{20}{24}$

i)  $\frac{13}{16} < \frac{44}{48}$

**C 166**

Brøkform	Desimalform
$\frac{2}{3}$	0,67
$\frac{3}{4}$	0,75
$\frac{1}{3}$	0,33
$\frac{3}{5}$	0,60
$\frac{7}{4}$	1,75
$\frac{7}{3}$	2,33

**C 168**

- a) 0,83                      b) 0,67                      c) 0,43                      d) 0,56  
e) 0,89                      f) 0,62                      g) 0,58

**C 169**

- a)  $\frac{4}{5} > \frac{7}{9}$                       b)  $\frac{3}{4} < 0,8$                       c)  $\frac{2}{3} < 0,7$                       d)  $\frac{5}{9} < \frac{9}{13}$   
e)  $0,55 > \frac{8}{15}$                       f)  $0,7 > \frac{5}{8}$                       g)  $\frac{6}{6} = 1$                       h)  $\frac{2}{3} < 0,67$   
i)  $\frac{6}{11} > \frac{8}{15}$

**C 170**

- a) 0,63                      b) 2,60                      c) 0,44                      d) 0,78  
e) 2,29                      f) 3,17                      g) 0,45                      h) 0,81

**C 171**

- a)  $0,71 > 0,70$                       b)  $0,55 < 0,56$                       c)  $1,80 < 1,85$                       d)  $0,42 < 0,45$   
e)  $2,83 > 2,75$                       f)  $1,71 < 1,78$

**C 172**

- a) 0,3                      b) 0,7                      c) 0,9                      d) 1,3  
e) 2,3                      f) 6,9                      g) 0,82                      h) 0,26

**C 173**

- a)  $\frac{4}{10}$                       b)  $\frac{7}{10}$                       c)  $\frac{1}{10}$                       d)  $\frac{35}{100}$   
e)  $\frac{369}{100}$                       f)  $\frac{553}{1000}$                       g)  $\frac{334}{1000}$                       h)  $\frac{8}{1000}$

**C 174**

- a) En uekte brøk er en brøk der teller er større enn nevner for eksempel  $\frac{3}{2}$ .  
b) Et blandet tall er et helt tall pluss en ekte brøk. Vi skriver for eksempel  $1\frac{7}{10}$  som betyr  $1 + \frac{7}{10}$ .

**C 175**

- a)  $\frac{5}{4}$                       b)  $\frac{11}{3}$                       c)  $\frac{35}{6}$                       d)  $\frac{35}{3}$

**C 176**

- a)  $1\frac{2}{3}$                       b)  $1\frac{2}{5}$                       c)  $3\frac{1}{5}$                       d)  $5\frac{3}{4}$

**C 180**

- a) Det er det samme som å gange tallet med 5./  
Det er det same som å gonge talet med 5.  
b) Det er det samme som å dele tallet på 5./Det er det same som å dele talet på 5.  
c) Tallet forblir uendret./Talet forblir uendra.

<b>C 181</b>	a) 6 mnd.	b) 8 mnd.	c) 9 mnd.	d) 10 mnd.
<b>C 182</b>	a) 30 min	b) 15 min	c) 45 min	d) 36 min
<b>C 183</b>	a) 9 timer/9 timar		b) 15 timer/15 timar	
<b>C 184</b>	a) 26 %	b) 37 %	c) 62 %	
<b>C 185</b>	a) 25 %	b) 32 %	c) 40 %	d) 37,5 %
<b>C 186</b>	a) 25 %	b) 75 %		
<b>C 187</b>	20 %		<b>C 188</b>	33,3 %
<b>C 189</b>	2,5 %		<b>C 190</b>	65 %
<b>C 191</b>	30 %			
<b>C 192</b>	a) 94 %	b) 83 %	c) 100 %	d) 72 %
<b>C 193</b>	a) 5 kr	b) 25 kr	c) 125 kr	d) 60 kr
	e) 6 kr	f) 2,50 kr		
<b>C 194</b>	a) 60 m	b) 35 kr	c) 120 træer/tre	d) 1,5 kg
	e) 1,92 m	f) 0,16 dl		



**C 195**

Brøkform	Desimalform	Prosentform
$\frac{1}{4}$	0,25	25 %
$\frac{1}{5}$	0,20	20 %
$\frac{3}{4}$	0,75	75 %
$\frac{4}{5}$	0,80	80 %
$\frac{9}{10}$	0,90	90 %
$\frac{43}{100}$	0,43	43 %
$\frac{115}{100}$	1,15	115 %

**C 196**

- a)  $\frac{16}{100}$       b)  $\frac{82}{100}$       c)  $\frac{8}{100}$       d)  $\frac{115}{100}$

**C 197**

- a) 0,13      b) 0,92      c) 0,07      d) 1,06

**C 198**

- a)  $\frac{73}{100} = 0,73$       b)  $\frac{28}{100} = 0,28$       c)  $\frac{132}{100} = 1,32$       d)  $\frac{4}{100} = 0,04$

**C 199**

- a) 78 elever/  
elevar      b) 10 kr      c) 18 epler/  
eple      d) 36 lys
- e) 7 500 kr      f) 375,30 kr      g) 253 liter      h) 168,75 tonn

**C 200**

- a) 39      b) 611

**C 201**

- a) 48 kr      b) 30 kr      c) 42 kr

**C 202**

- a) 21      b) 39

**C 203**

3 348 kr

<b>C 204</b>	a) 102	b) 48		
<b>C 205</b>	123	<b>C 206</b>	376 kr	
<b>C 207</b>	429 kr			
<b>C 208</b>	a) 1 007 biler/ bilar	b) 731 biler/ bilar	d) 2 639 biler/ bilar	e) 4 049 biler/ bilar
<b>C 209</b>	a) 1 250 kWh	b) 5 500 kWh	d) 13 500 kWh	e) 1 000 kWh
<b>C 210</b>	6 148 kr	<b>C 211</b>	2 646 kr	
<b>C 212</b>	a) 1 743 kr	b) 1 449 kr		
<b>C 213</b>	1 431 kr	<b>C 214</b>	3 036 filmer/filmar	
<b>C 215</b>	3 445 kr			
<b>C 216</b>	a) 648 kr	b) 10 152 kr		
<b>C 217</b>	a) 2 173 kr	b) 1 517 kr	c) 7 995 kr	
<b>C 218</b>	33,3 %	<b>C 219</b>	20 %	
<b>C 220</b>	18,75 %			
<b>C 221</b>	a) 31,2 kg	b) 88,8 kg		
<b>C 222</b>	2 977 kr	<b>C 223</b>	70 kr	
<b>C 224</b>	a) 104 000 kr	b) 1 704 000 kr		

**C 225**

- a) 125 625 kr      b) 1 549 375 kr

**RØD/RAUD****C 226**

- a)  $\frac{3}{12}$       b)  $\frac{7}{18}$       c)  $\frac{1}{2}$       d)  $\frac{3}{8}$

**C 227**

- a)  $\frac{1}{16}$   
c)  $\frac{1}{8}$

b)

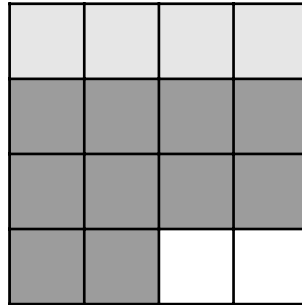
**C 228**

- a)  $\frac{21}{26}$       b)  $\frac{5}{26}$

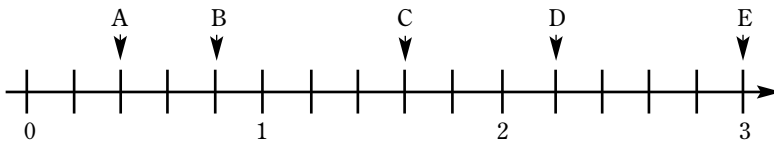
**C 229****C 230**

- a)  $\frac{11}{38}$       b)  $\frac{27}{38}$

**C 231**

- a) 0,3      b) 0,031      c) 5,009

**C 232**

- a)  $\frac{6}{10}$       b)  $\frac{1}{10}$       c)  $\frac{15}{100}$       d)  $\frac{9}{100}$   
e)  $\frac{81}{100}$       f)  $\frac{32}{1000}$       g)  $\frac{245}{100}$       h)  $\frac{52}{1000}$   
i)  $\frac{3}{1000}$       j)  $\frac{2038}{1000}$       k)  $\frac{52}{10000}$       l)  $\frac{32}{10}$

**C 234**

- a) 0,57      b) 0,55      c) 0,78      d) 0,89

**C 235**

- a)  $\frac{4}{7} < \frac{5}{8}$       b)  $\frac{6}{11} < \frac{5}{9}$       c)  $0,63 < \frac{7}{11}$       d)  $\frac{9}{17} > \frac{22}{47}$   
e)  $\frac{8}{13} < 0,72$       f)  $0,17 < \frac{2}{9}$

**C 236**

a)  $\frac{15}{6} = \frac{75}{30}$

b)  $\frac{3}{5} = \frac{33}{55}$

c)  $\frac{6}{7} = \frac{72}{84}$

d)  $\frac{4}{9} = \frac{52}{117}$

e)  $\frac{14}{7} = \frac{238}{119}$

f)  $\frac{19}{7} = \frac{152}{56}$

g)  $\frac{81}{27} = \frac{9}{3}$

h)  $\frac{32}{72} = \frac{4}{9}$

**C 237**

a) ca.  $\frac{7}{9}$

b) ca.  $\frac{5}{9}$

c) ca.  $\frac{12}{18}$

d) ca.  $\frac{6}{18}$

**C 238**

a)  $\frac{56}{64}$

b)  $\frac{106}{64}$

c)  $\frac{176}{64}$

d)  $\frac{92}{64}$

e)  $\frac{144}{64}$

**C 239**

a)  $\frac{36}{22}$

b)  $\frac{36}{138}$

c)  $\frac{36}{60}$

d)  $\frac{36}{56}$

e)  $\frac{36}{156}$

**C 240**

a)  $\frac{6}{30}$

b)  $\frac{3}{15}$

c)  $\frac{2}{10}$

d)  $\frac{1}{5}$

e)  $\frac{4}{20}$

**C 241**

a)  $\frac{10}{9}$

b)  $\frac{30}{27}$

**C 242**

a)  $\frac{30}{35} = \frac{6}{7}$

b)  $\frac{42}{56} = \frac{3}{4}$

c)  $\frac{68}{119} = \frac{4}{7}$

d)  $\frac{120}{85} = \frac{24}{17}$

e)  $\frac{78}{26} = \frac{3}{1}$

f)  $\frac{42}{70} = \frac{3}{5}$

g)  $\frac{152}{184} = \frac{19}{23}$

h)  $\frac{56}{264} = \frac{7}{33}$

**C 243**

357 kan deles med 3

6 224 kan deles med 2 og 4

8 091 kan deles med 3 og 9

1 344 kan deles med 2, 3 og 4

3 951 kan deles med 3 og 9

2580 kan deles med 2, 3, 4 og 5

**C 244**

- a)  $\frac{17}{26}$       b)  $\frac{3}{17}$       c)  $\frac{69}{37}$       d)  $\frac{58}{67}$
- e)  $\frac{318}{359}$

**C 245**

- a)  $\frac{71}{8}$       b)  $\frac{63}{5}$       c)  $\frac{51}{16}$       d)  $\frac{366}{23}$

**C 246**

- a)  $1\frac{1}{224}$       b)  $21\frac{3}{15}$       c)  $11\frac{5}{9}$       d)  $26\frac{6}{12}$

**C 247**

- a) 30 %      b) 25 %

**C 248**

Brøkform	Desimalform	Prosentform
$\frac{3}{4}$	0,75	75 %
$\frac{1}{8}$	0,125	12,5 %
$\frac{1}{6}$	0,17	17 %
$\frac{67}{100}$	0,67	67 %
$\frac{87}{100}$	0,87	87 %
$\frac{125}{100}$	1,25	125 %

**C 249**

- a) 94 %      b) 77 %      c) 82 %      d) 100 %

**C 250**

- a) 2,5 tonn      b) 8 tilskuere/tilskodarar  
c) 4,10 kr      d) 29 klinkekuler

**C 251**

- a)  $\frac{82}{100}$       b)  $\frac{7}{100}$       c)  $\frac{132}{100}$       d)  $\frac{352}{100}$

**C 252**

- a) 0,03                      b) 0,08                      c) 0,73                      d) 3,20  
 e) 1,16                      f) 0,01

**C 253**

- a) 2 788 biler/bilar                      b) 382 biler/bilar  
 c) 138 biler/bilar                      d) 721 biler/bilar

**C 254**

	Forbruk i %	Forbruk i kWh
Oppvarming	54	13 500
Lys	5	1 250
Støvsugning	1	250
Vask og stryking	6	1 500
Matlaging	8	2 000
Kjøleskap og fryser/ frysar	4	1 000
Varmt vann og bad/ Varmt vatn og bad	22	5 500

**C 255**

477 kr

**C 256**

6 153 kr mennesker/menneske

**C 257**

7 272 besøkende/besøkjande

**C 258**

- a) 1) 5 151,60 kr                      b) 7 735,98 kr  
 2) 609,90 kr  
 3) 1 728,48 kr  
 4) 246 kr

**C 259**

4 524 kr

**C 260**

3 854 kr

**C 261**

14 624 kr

**C 262**

114 807 besøkende/besøkjande

**C 263**

2 281 kr

**C 264**

- a) 41,7 %                      b) 16,7 %                      c) 14,3 %

**C 265**

600 kr

**C 266**

25 %

**C 267**

25 %

**C 268**

15 %

**C 269**

20 %

**C 270**

6,7 %

**C 271**

Trolloil gir 30 %

**PRØV DEG SELV/PRØV DEG SJØLV****PC 1**

$$\frac{8}{24}$$

**PC 2**

a)  $\frac{1}{3}$

b)  $\frac{5}{11}$

c)  $\frac{15}{46}$

**PC 3**

a)  $\frac{1}{2} = \frac{12}{24}$

b)  $\frac{1}{4} = \frac{6}{24}$

c)  $\frac{3}{8} = \frac{9}{24}$

**PC 4**

$$\frac{4}{6}, \frac{8}{12} \text{ og } \frac{16}{24}$$

**PC 5**

a)  $\frac{3}{14} < \frac{7}{14}$

b)  $\frac{1}{9} = \frac{3}{27}$

c)  $\frac{3}{4} < \frac{7}{5}$

d)  $\frac{8}{11} > \frac{9}{44}$

**PC 6**

a)  $18 \frac{2}{3}$

b)  $69 \frac{1}{2}$

**PC 7**

$$\frac{1}{100}$$

**PC 8**

25 %

**PC 9**

35 %

**PC 10**

a)  $\frac{10}{100}$

b)  $\frac{8}{100}$

**PC 11**

a) 0,48

b) 0,01

**PC 12**

a) 18 %

b) 6 %

PC 13

a) 21 kr

b) 3,5 liter

PC 14

175 kr

PC 15

a) 7,25 m

b) 0,325 km

PC 16

949 kr

PC 17

4 388 kr

## FYLKESOPPGAVE SØR-TRØNDELAG/ FYLKESOPPGÅVE SØR-TRØNDELAG

FC 1

a) Trondheim

b) 116 406 innbyggere/innbyggjarar

FC 2

994 år

FC 3

a) 1987

b) 1654

FC 4

a) 485 muh.

b) 725 muh.

FC 5

Du må vite hvor stort Norge er. Hun eide 162 110 m<sup>2</sup>.  
(ikke inkludert Svalbard og Dronning Maud Land)/  
Du må vite kor stort Noreg er. Ho åtte 162 110 m<sup>2</sup>.  
(ikkje inkludert Svalbard og Dronning Maud Land)/

FC 6

a) 6 400 kr

b) 5 650 kr